



W713B Series Intelligent Controller for Water Pump User Manual



GUANGZHOU BEDFORD ELECTRIC EQUIPMENT CO.,LTD.

V1.0.0

Preface

Thanks for choosing our product W713B, we will supply you with considerate service as well as ever.

W713B series products are not only the integrated intelligent controller designed for water pump, but also the intelligent controller designed for the central air-conditioning water circulation system to realize the differential constant pressure control.

W713B intelligent controller has superior performance and rich use function, can meet the requirement of water supply and drainage on various occasions and improve the quality of water supply system. The product adopts the control method of one pump and one variable frequency controller, which can effectively extend the motor service life; the controller system supports max.6 pumps linkage work, meet the customers' operating requirements.

With high quality, multi-functional, low noise and strong commonality etc. characteristics, W713B multi-function energy-saving controller is suitable to full-automatic operation.

- Suitable for various constant pressure/constant differential pressure/constant temperature/constant differential temperature water supply applications.
- After parameters were set correctly, the system can operate automatically with constant pressure/constant differential pressure/constant temperature/constant differential temperature according to the water consumption without manual operation;
- Alternate running automatically in the multiple pump system, prolong the using life of pumps.
- Restart automatically when power recovery
- Stop running automatically when no water consumption;
- Alarm automatically when faults occurred;
- Suitable for various pressure signals input.

Contents

1. SAFETY PRECAUTIONS	1
2. PRODUCT INTRODUCTION	2
2.1 Features	2
2.2 Model Specification	2
2.3 Selection Guide	3
2.4 Check the Following Point	3
2.5 External Dimension	4
3. ENVIRONMENTAL REQUIREMENT	4
4. WIRING	5
4.1 Main Circuit Terminals Wiring	5
4.2 Control Circuits Terminals Wiring	5
4.3 Control Terminals Overall Connect	7
4.4 Wiring Main Circuits	7
4.4.1 Wiring of Main Circuits	7
4.4.2 Circuit Breaker	7
4.4.3 AC Reactor (Optional)	8
4.4.4 Input EMC Filter (Optional)	8
4.4.5 Output EMC Filter (Optional)	8
4.4.6 Output Reactor	8
4.4.7 Ground Wiring	8
5. OPERATION	8
5.1 Keypad Description	8
5.2 Operation Procedure	9
5.2.1 Add Prefix Characters Display Content for Easy Understanding ..	9
5.2.2 Power-on Initialization	9
5.2.3 Parameter Setting	9

6. INSTRUCTIONS OF PARAMETERS GROUP	11
7. QUICK DEBUG of PARAMETER SETTING	28
8. APPLICATION GUIDANCE	33
8.1 Application of Constant Pressure Water Supply	33
8.1.1 Single Pump Water Supply and Parameter Setting	33
8.1.1.1 System Wiring	33
8.1.1.2 System Debugging Procedure	34
8.1.1.3 Relevant Parameter Setting	34
8.1.2 Multi-pump Control	35
8.1.2.1 Typical System Wiring	35
8.1.2.2 Relevant Parameter Setting	36
8.2 Application of Constant Differential Pressure Water Supply	39
8.2.1 Differential Pressure Control System Introduction.	39
8.2.2 Typical System Wiring	40
8.2.3 System Debugging Procedure	41
8.2.4 Relevant Parameter Setting	41
8.3 Application of Constant Temperature Water Supply	44
8.3.1 Single Pump Water Supply and Parameter Setting	44
8.3.1.1 System Wiring	44
8.3.1.2 System Debugging Procedure	44
8.3.1.3 Relevant Parameter Setting	45
8.3.2 Multi-pump Control	45
8.3.2.1 Typical System Wiring	45
8.3.2.2 Relevant Parameter Setting	46
8.4 Application of Constant Differential Temperature Water Supply	49
8.4.1 Differential Temperature Control System Introduction.	49
8.4.2 Typical System Wiring	50
8.4.3 System Debugging Procedure	51
8.4.4 Relevant Parameter Setting	51

8.5 Manual/Auto Control Wiring and Setting	54
8.5.1 System Wiring	54
8.5.2 Operation	55
8.5.3 Relevant Parameter Setting	55
8.6 Electric Contact Gauge Water Supply	55
8.6.1 System Wiring	55
8.6.2 Relevant Parameter Setting	56
8.6.3 Relevant Parameter Setting	56
8.7 Application of One VFD Drive Two Pump	56
8.7.1 Relevant Parameter Setting	56
8.7.2 System Debugging Procedure	58
8.7.3 Relevant Parameter Setting	58
8.8 Application Summary	60
9. FAULT AND TROUBLE SHOOTING	60
9.1 System Running Fault and Trouble Shooting	60
9.2 Water Supply Running Fault and Trouble Shooting	61
9.3 Controller Running Fault and Trouble Shooting	62
9. COMMUNICATION PROTOCOL	63

1. SAFETY PRECAUTIONS

W713B is a new power electronic product, please read the operation manual carefully before using to keep your safety and make sure proper operation.

In this manual, the safety precautions were sorted to “**WARNING**” and “**CAUTION**”.

 **WARNING:** Wrong using may result in death or serious personal injury.

 **CAUTION:** Wrong using may result in the damage of controller or system.

WARNING

- Please don't dismantle, change the product, or may cause electric shock, fire hazard and personal injury;
- Please don't open the cover during the running of controller;
- Please don't put wire, bar of metal, filaments etc. into the controller so as not to cause a short circuit or get an electric shock;
- Please don't splash water or other liquid over the controller.

CAUTION

- Please don't make withstand voltage testing for the controller;
- Never connect AC power to output UVW terminals;
- If the internal components of the controller were influenced or damaged by static, please do not to touch;
- The motor, controller and power specifications should be matching, otherwise it could cause abnormal operation even burn out the device;
- If the controller appears serious vibration, noise, heat or peculiar smell in the first operation, please cut off the power immediately and contact suppliers or service center later;
- Please don't install the controller in the environment with direct sunlight, rain, frost or snow in case of deformation or damage.

Warm reminder:

For convenience, the controller has set default with a nonzero AI1 feedback lost detecting value, if here hasn't pressure signal feedback into the terminal AI1, the controller will be starting up failure and displaying “E022”, just take follows:

◇ If the controller worked as a master, please connect a transducer to the controller and then press the  key;

◇ If it worked as an auxiliary, it should be setting as AI1 feedback lost detecting value (b02.08) 0 and then pressing the  key to reset error warning.

2. PRODUCT INTRODUCTION

2.1 Features

● Input & Output

- ◆ Input Voltage Range: 220V/380V±15%
- ◆ Input Frequency Range: 47~63Hz
- ◆ Output Voltage Range: 0~rated input voltage
- ◆ Output Frequency Range: 0~50/60Hz

● I/O Features

- ◆ Digital Switch Input: 4 input
- ◆ Analog Signal Input: AI1: 0~10V or 0/4~20mA input; AI2: 0~10V or 0/4~20mA input
- ◆ Relay Output: Two pair of switch output

● Function Characteristics

- ◆ Multi-Pumps Control Function: Max.6 pump linkage water supply
- ◆ Sleep Function: Sleep down when have no water consumption, to earn a better energy saving
- ◆ Freeze-Proofing Function: Suitable to low temperature area, prevent pump from freezing
- ◆ Anti-clogging Function: Take precaution against pipe clogging and clean the pipe dirt
- ◆ Power On Restart: Running automatically when power on
- ◆ Master Fault Shift Automatically: Keep on working when the master break down
- ◆ Alternate Running: Balance every pump's running time, prolong service life of the whole unit machine
- ◆ Control Mode: Constant pressure, constant differential pressure, constant temperature, constant differential temperature, manual
- ◆ Linkage Mode: Synchronize, master-slave, big-small pump combination, one duty one standby, one VFD drives two pump (in conjunction with control electric cabinet).
- ◆ Terminal Control Mode: Electronic contact gauge control, manual/auto control, terminal run/stop, automatic water level control, one VFD drives two pump fault input.
- ◆ Various of Water Supply Fault Alarm Function: High-pressure, low-pressure, low-level, transducer error etc.
- ◆ Many Fault Protection Function: Over-current, over-voltage, low-voltage, phase-failure, over-Load etc.
- ◆ Scalability: Can be connected to our company touch screen(HMI)

2.2 Model Specification

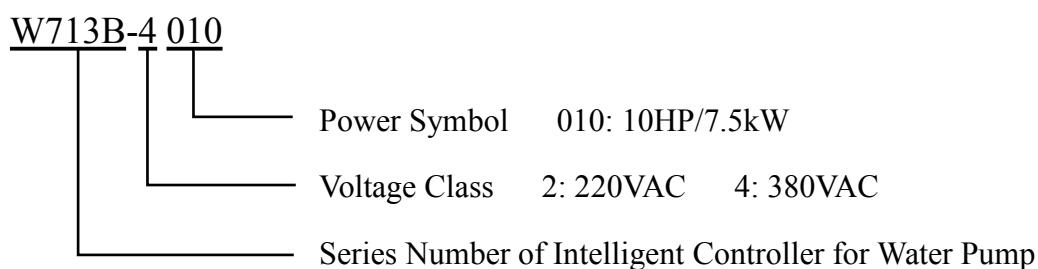

2.3 Selection Guide

Table2.3.1 W713B list

Model No.	Rated Input Voltage (V)	Rated Input Current (A)	Rated Output Current (A)	Motor Power (kW)
W713B-2001	1AC: 220V -15%~+15%	7.1	4.5	0.75
W713B-2002		11.1	7.0	1.5
W713B-2003		15.8	10.0	2.2
W713B-2001	3AC: 220V -15%~+15%	7.1	4.5	0.75
W713B-2002		11.1	7.0	1.5
W713B-2003		15.8	10.0	2.2
W713B-2004		17.6	13.0	3.0
W713B-2005		23.0	17.0	3.7
W713B-2007		32.0	25.0	5.5
W713B-2010		40.0	32.0	7.5
W713B-4001		3AC: 380V -15%~+15%	3.4	2.1
W713B-4002	5.0		3.8	1.5
W713B-4003	5.8		5.1	2.2
W713B-4004	13.5		9.5	4.0
W713B-4005	19.5		14.0	5.5
W713B-4007	25.0		18.5	7.5
W713B-4010	32.0		25.0	11.0
W713B-4015	40.0		32.0	15.0
W713B-4020	47.0		38.0	18.5

2.4 Check the Following Point

- Inspect the nameplate and ensure it meets the order type and specification;
- Inspect the entire exterior of the controller to ensure there are no scratches or other damage caused by the transportation;
- Ensure the guarantee odd number matches the controller;
- If you have found any problem mentioned above, please contact the supplier.

2.5 External Dimension

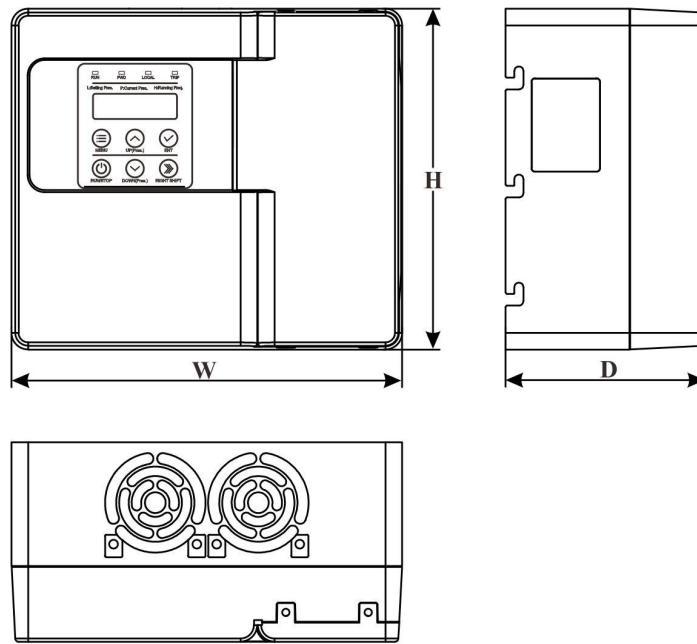

Figure 2.5.1 Dimension

Model (kW)	External Dimension		
	H (mm)	W (mm)	D (mm)
220V: 0.75~2.2 (380V: 0.75~3.0)	170	190	110
220V: 3.0~3.7 (380V: 4.0~7.5)	205	235	120
220V: 5.5~7.5 (380V: 11.0~18.5)	220	290	150

3. ENVIRONMENTAL REQUIREMENT

1. Environment temperature range: $-10^{\circ}\text{C} \sim 40^{\circ}\text{C}$, controller will be derated at 4% on every 1°C if ambient temperature exceeds 40°C , the maximum temperature is less than 50°C .
2. Prevent rain drops, moist environment, oil fog, salt erosion, corrosive gas, etc..
3. Prevent direct sunlight, keep away from radiation source.
4. Prevent violent vibration or sudden impact.
5. Lower than 1000m installation altitude, if exceeds 1000m, inverter will be derated at 1% on every 100m.

CAUTION

- When moving the controller please lift by its base and don't lift by the panel. Otherwise may cause the main unit fall off which may result in personal injury.
- Install the controller on the fireproofing material (such as metal) to prevent fire.
- When power off, should not install the controller until the power indicator light was extinguished, which can ensure the device has been discharged completely.
- Disconnect all power line before opening front cover of unit. Wait at least 5 minute until DC Bus capacitors discharge.

4. WIRING

4.1 Main Circuit Terminals Wiring



Figure 4.1.1 The main circuit terminals

2. Main circuit terminal's function as following:

Terminal Symbol	Function Description
L, N	Terminals of single phase AC input
R, S, T	Terminals of 3 phase AC input
U, V, W	Motor wiring terminal
PE	Terminals of ground

In order to keep safety and prevent electric shock and fire, “PE” must be grounded with ground resistance. Furthermore, reliable grounding is the simplest, most effective and minimum cost solution for EMC problems, so it enjoys priority in all EMC methods.

4.2 Control Circuits Terminals Wiring

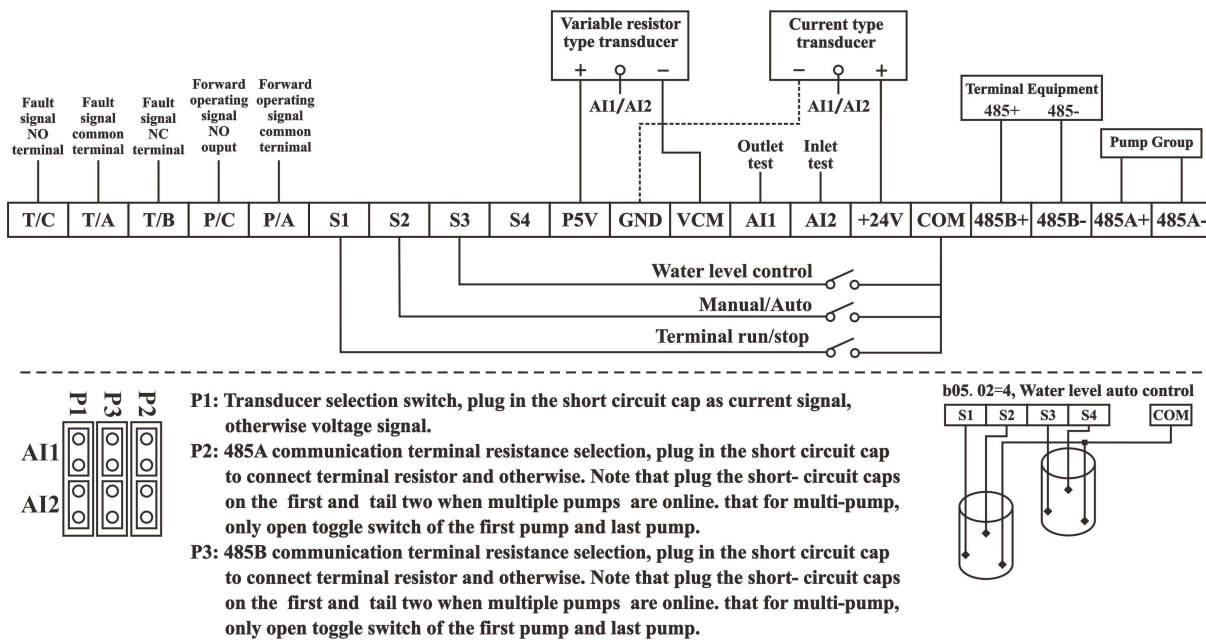





Figure 4.2.1 Control circuits terminals wiring



Manual/Auto Switchover Function (Constant Speed/Constant Pressure (Constant Differential Pressure/Constant Temperature/Constant Differential Temperature) Switchover Function):

(1) Terminal (Terminal in priority, panel keypad control manual/auto switchover invalid)

When b05.02 = 2, S2 disconnected with COM, and constant pressure/constant differential pressure/constant temperature/constant differential temperature water

supply is provided. The set pressure/differential pressure/temperature/differential temperature under the primary interface can be adjusted by pressing  or  key. S2 connected with COM, operate and supply water at constant speed, and the constant speed operation frequency under the primary interface can be adjusted by pressing  or  key.

(2) Panel Keypad (Manual/Auto Switchover can be realized by pressing the panel button when the inverter is stopped)

In the stop state, press the  and  key at the same time in the primary display interface to realize the manual/automatic switchover.

The functions of the control terminal are described below:

Type	Terminal symbol	Terminal Name	Function Description	
Power Source	P5V-VCM	10mA output terminal (Load is less than 1kΩ)	Providing 10mA current (Load is less than 1kΩ), used for external resistance type remote pressure gauge	
	+24V-GND	24V power source	Providing 24V power source, used for pressure transmitter, the max.output current	
Analog Input	+24V-AI1	Analog input terminal 1	Reception of 0/4mA~20mA pressure transmitter, Plug in jumper cap on control panel P1.	
	+24V-AI2	Analog input terminal 2		
Digital Input	S1-COM	Digital Input 1	ON-OFF signal input, optical coupling with +24V and COM Input voltage range: 9V~30V Input impedance: 2.4kΩ	
	S2-COM	Digital Input 2		
	S3-COM	Digital Input 3		
	S4-COM	Digital Input 4		
Relay Output	T/A-T/B	NC terminal	The relay switch contact signal, which can be either alarm or valve switch signals.Max.capacity of contact: AC 250V- 3A or DC 30V-1A.	
	T/A-T/C	NO terminal		
	P/A-P/C	NO terminal		
Communication	485A+	First pair RS485 communication terminal	485 communication interface and internal communication interface, please use twisted pair or shield wire	
	485A-			
	485B+	Second pair RS485 communication terminal		485 communication interface and external communication interface, please use twisted pair or shield wire
	485B-			
Remarks	P1	The AI1 and AI2 input type selector switch	Plug in the short circuit cap as current signal, otherwise voltage signal	
	P2	485B communication terminal resistance selection	Plug the short circuit cap to connect the terminal resistance and otherwise. Note that plug the short-circuit caps on the first and tail two when multiple pumps are online. that for multi-pump, only open toggle switch of the first pump and last pump.	
	P3	485A communication terminal resistance selection		

4.3 Control Terminals Overall Connect

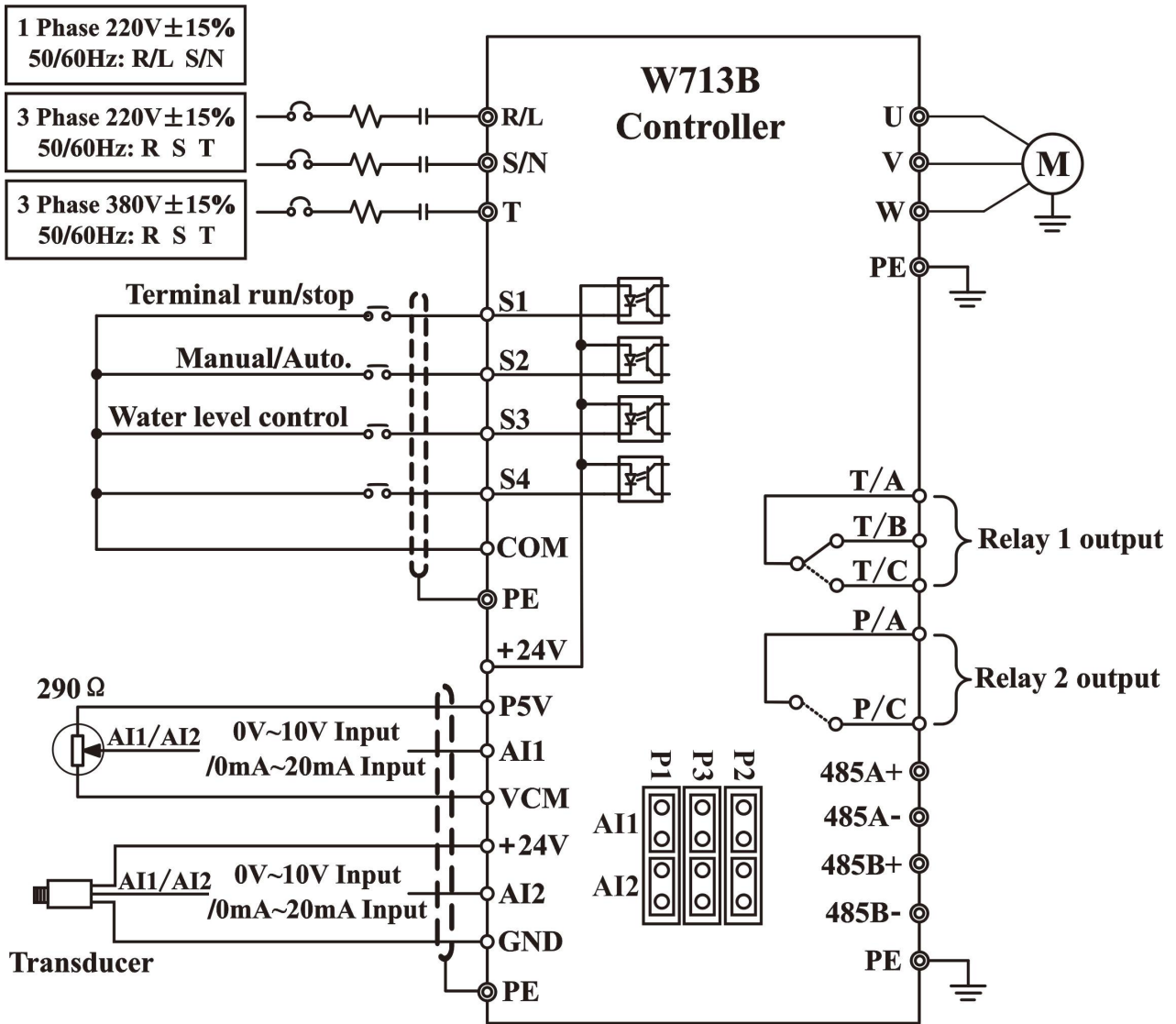

Figure 4.3.1 Wiring diagram

4.4 Wiring Main Circuits

4.4.1 Wiring of Main Circuits

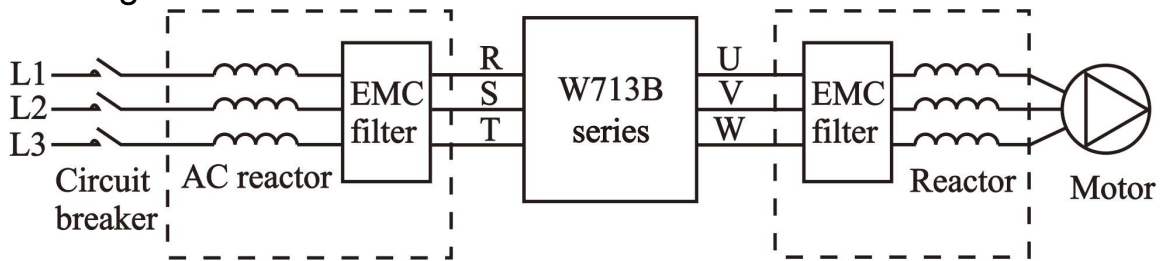

Figure 4.4.1 High-performance main circuit wiring

4.4.2 Circuit Breaker

It is necessary to connect a suitable circuit breaker between 3 phase AC power supply and W713B series intelligent constant water supply controller. The capacity of breaker is 1.5~2 times to the rated current of controller.

4.4.3 AC Reactor (Optional)

In order to prevent the rectifier damage resulted from the large current, AC reactor should be installed at the input side. It can also prevent rectifier from sudden variation of power voltage or harmonic generated by phase-control load.

4.4.4 Input EMC Filter (Optional)

EMC filter can minimize the interference of the surrounding device which may be disturbed by the cables when the controller is working.

4.4.5 Output EMC Filter (Optional)

EMC filter should be installed to minimize the leak current caused by the cable and minimize the radio noise caused by the cables between the controller and motor.

4.4.6 Output Reactor

When the distance between the W713B controller and motor is more than 50m, the controller may be tripped by over-current protection frequently because of the large leak current resulted from the parasitic capacitance with ground. So as to avoid the damage of motor insulation, the output reactor should be installed.

4.4.7 Ground Wiring

In order to keep safety and prevent electric shock and fire, “PE” must be grounded with ground resistance. Furthermore, reliable grounding is the simplest, most effective and minimum cost solution for EMC problems, so it enjoys priority in all EMC methods.

5. OPERATION

5.1 Keypad Description

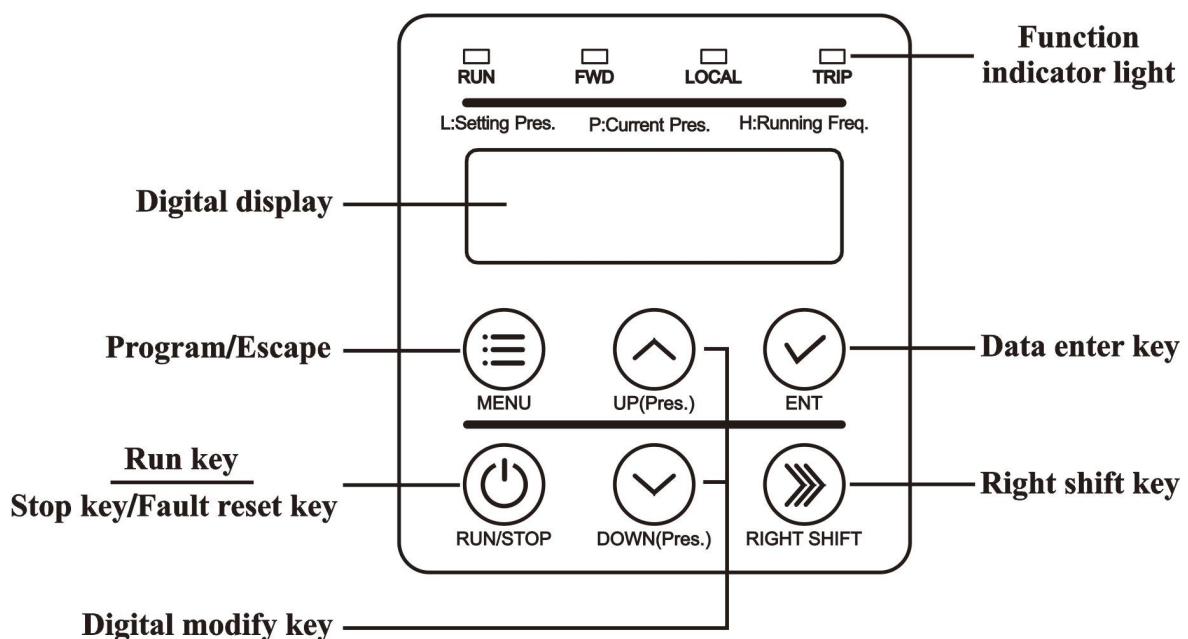

Figure5.1.1 Keypad schematic diagram

5.2 Operation Procedure

5.2.1 Add Prefix Characters Display Content for Easy Understanding

H: Operating Frequency

P: The Actual Pressure of Pump Outlet

/The Actual Differential Pressure (Outlet Pressure -Inlet Pressure)

/The Actual Temperature of Pump Outlet

/The Actual Differential Temperature (Outlet Temperature - Inlet Temperature)

L: The Setting Pressure of Pump Outlet

/The Setting Differential Pressure (Outlet Pressure -Inlet Pressure)

T: The Setting Temperature of Pump Outlet

/The Setting Differential Temperature (Outlet Temperature -Inlet Temperature)

A: Output current

d: DC Bus Voltage

3.0 - 0.0

: The Setting Pressure of Pump Outlet and Actual Pressure of Pump Outlet

/The Setting Differential Pressure and Actual Differential Pressure

/The Setting Temperature of Pump Outlet and Actual Temperature Pressure of Pump Outlet

/The Setting Differential Temperature and Actual Differential Temperature

0.0 _ 0.0

: The Output Current and The Actual Pressure of Pump Outlet

/The Output Current and Actual Differential Pressure

/The Output Current and Actual Temperature of Pump Outlet

/The Output Current and Actual Differential Temperature









5.2.2 Power-on Initialization

Firstly the system initializes during the controller power-on, and LED displays “713b”. After the initialization is completed, the controller is on stand-by status.

5.2.3 Parameter Setting

Three levels of menu are: 1. Function code group (first-level); 2. Function code (second-level); 3. Function code setting value (third-level)

- ▲ At the primary interface, press  will switch over display running/stop status monitoring parameters;

- ▲ At the primary interface, press  will enter the first-level menu then press  will return to the primary interface;
- ▲ At the first-level menu, press  will enter the second-level menu. In second-level menu can also press  and  return to first-level menu or enter third-level menu;
- ▲ At third-level menu, press  or  can return to the second-level menu, difference is: pressing  will save the parameters into the controller and return to the second-level menu with shifting to the next function code automatically; while pressing  will directly return to the second-level menu without saving the parameters, and keep staying at the current function code.

Example 1: Change factory pressure setting 3.0 bar to 2.5 bar

Method 1: Enter parameter setting

Operation flow chart:

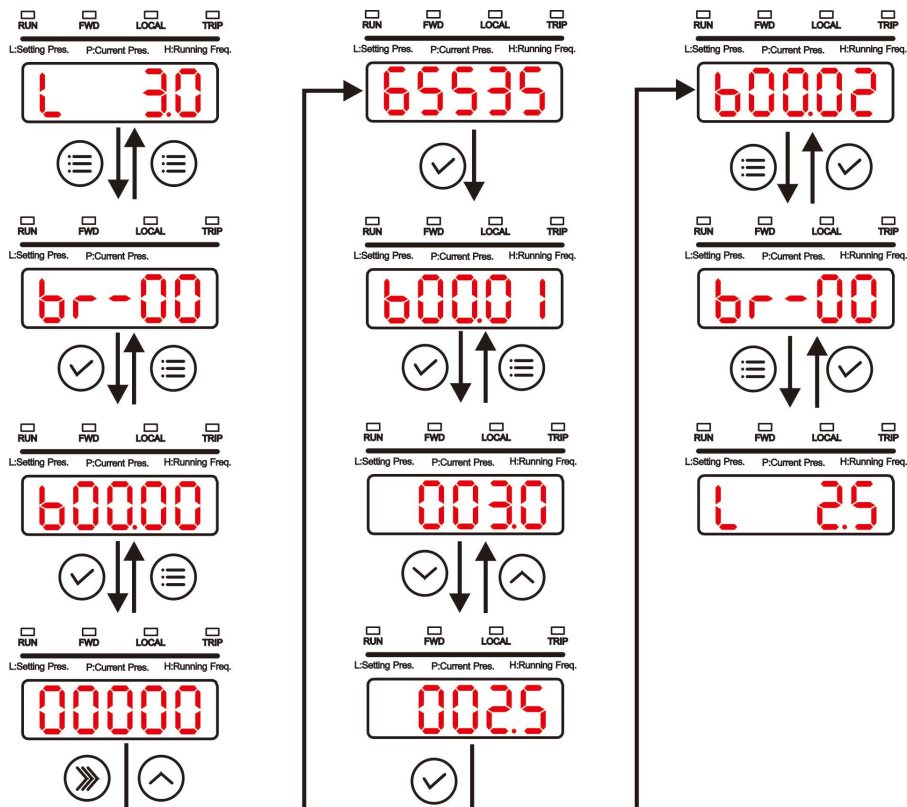





Figure 5.2.1 Operation flow chart

Method 2: Direct setting at the primary interface

Press  or  at primary interface, the system will switch-over to display setting pressure, press  or  again, the setting pressure increase/decrease, mean while the system trace the setting pressure.

6. INSTRUCTIONS OF PARAMETERS GROUP

“○”： stands for the inverter is in stop or running status,the parameter can be changed;

“◎”： stands for the inverter is in running status,the parameter can not be changed;

“●”： Stand for the parameter can not be changed.

Function Code	Name	Setting Range	Factory Setting	Description	R/W	Address
br-00 Group Application Function						
b00.00	Function Debugging Password	0~65535	65535	Decide by b06.09, default is 65535	—	—
b00.01	Pressure Setting	b01.01 ~b01.00-1.0	3.0bar	Set Pressure/Set Differential Pressure/Set Temperature/Set Differential Temperature According to mode (b01.18) selection and automatically adjust factory setting according to the responding mode.	○	0xB001
	Differential pressure setting	0.0 ~b01.00-1.0	0.5bar			
	Temperature Setting	-15.0	30.0°C			
	Differential Temperature	~b01.20-10	5.0°C			
b00.02	Setting Motor Rotating Direction	0~1	0	0: Forward; 1: Reverse	◎	0xB002
b00.03	Freeze-proofing	0~1	0	Used in cold areas. 0: Invalid; 1: Valid	◎	0xB003
b00.04	Anti-clogging	0~1	0	It is only suitable for single pump system to remove water pump rust blockage and pipeline blockage. 0: Invalid; 1: Valid	◎	0xB004
b00.05	Anti-clogging Rotating Cycle	1.0~300.0	20.0s	Set the forward/reverse rotating direction cycle and corresponding output frequency (should not be higher than the rated frequency of the pump) of anti-clogging.	○	0xB005
b00.06	Anti-clogging Output Frequency	0.00~b05.05	15.00Hz		○	0xB006
b00.07	Shortcut Key Setting	0x100 ~0x651	0x100	 <p>Fault shift, 0: forbidden; 1: on Master and Auxiliary IP, 0: Master; 1~5: Auxiliary Numbers of pump, 1~6</p>	◎	0xB007

Function Code	Name	Setting Range	Factory Setting	Description	R/W	Address
b00.08	Constant Speed Operating Frequency Setting Value	b05.07 ~b05.06	50.00Hz	When the constant speed operating frequency needs to be set to a greater value, the upper operating limit b05.06 shall be modified first, and then the value shall be modified	○	0xB008
b00.09	Manual Frequency Source Selection	0~3	0	0: Keyboard (b00.08); 1: AI1; 2: AI2; 3: Communications control	◎	0xB009
br-01 Group Application Function						
b01.00	High Water Pressure Alarm Value	b01.01+1.0 ~b01.05	8.0bar	When actual pressure on the outlet side is higher than this preset value, the inverter halts, alarms and displays “HP”. Constant Pressure Mode: When actual pressure on the outlet side is lower than this preset value, “HP” would be automatically cleared, When actual pressure on the outlet side is lower than the difference value between this preset value and bias value (b04.03), pump would restart automatically. Constant Differential Pressure Mode: When actual pressure on the outlet side is lower than the difference value between this preset value and 1.5 Bar, “HP” would be automatically cleared and pump would restart automatically.	○	0xB100
b01.01	Low Water Pressure Alarm Value	0.0~b01.00	0.5bar	Outlet side Low Water Pressure Alarm Preset Value	○	0xB101
b01.02	Low Pressure Running Time	0.0~3600.0	20.0s	When the “ Constant Pressure ” or “ Constant Differential Pressure ” Control Modes are in operation, the actual pressure on the outlet side is lower than the low water pressure alarm value (b01.01) for a low pressure running time (b01.02), the inverter halts, alarms and displays “LP”;	○	0xB102
	Low Temperature Running Time			When the “ Constant Temperature ” or “ Constant Differential Temperature ” Control Modes are in operation, the actual temperature on the outlet side is lower than the low temperature alarm value (b01.29) for a low temperature running time (b01.02), the inverter halts, alarms and displays “LT”.		

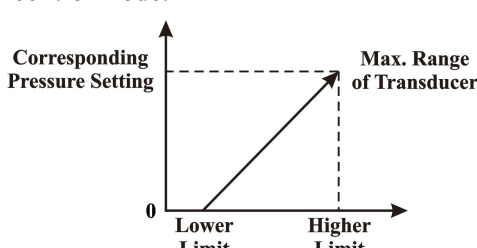
Function Code	Name	Setting Range	Factory Setting	Description	R/W	Address
b01.03	Minimum Freeze-proofing Frequency	1.00~b05.07	5.00Hz	Be valid when b00.03 was set to 1, when sleep, running with the setting frequency in case of freezing. This value should be lower than the lower limited frequency (b05.07).	○	0xB103
b01.04	Anti-clogging FWD./REV. Dead Time	0.0~3600.0	1.0s	When anti-clogging is valid, b01.04 set the FWD./REV. transition time	○	0xB104
b01.05	Maximum Transducer Setting Range	0.0~100.0	10.0bar	For “Constant Pressure” or “Constant Differential Pressure” Control Mode. If the rated max. range of transducer is 16.0bar, b01.05 should be set to 16.0; Set the control range of “Constant Temperature” or “Constant Differential Temperature” in parameters b01.07 and b01.09 (water outlet), b01.12 and b01.14 (water inlet).	○	0xB105
b01.06	AI1 Lower Limit	0.00~b01.08	1.00V	◆Lower limit (b01.06, b01.11) use to transducer zero setting	○	0xB106
b01.07	Corresponding Setting of AI1 Lower Limit	-100.0~200.0	0.0%	◆Corresponding Setting of Lower Limit (b01.07, b01.12) use to transducer minimum setting	○	0xB107
	AI1 Temperature Lower Limit		0.0℃	◆Higher limit (b01.08, b01.13) use to accordant display and transducer: when display smaller than the actual, decrease higher limit; when display greater than the actual, increase higher limit		
b01.08	AI1 Higher Limit	b01.06 ~10.00	5.00V		○	0xB108
b01.09	Corresponding Setting of AI1 Higher Limit	-100.0~200.0	100.0%	◆Corresponding Setting of Higher Limit (b01.09, b01.14) use to transducer maximum setting	○	0xB109
	AI1 Temperature Higher Limit		100.0℃	◆When analog input is interfered, prolong filtering time so as to increase the ability of anti-interference, but decrease the sensitivity.		
b01.10	AI1 Filtering Time	0.00~10.00	0.10s	◆Corresponding relationship of transducer parameter setting of “Constant Pressure” and “Constant Differential Pressure” control mode:	○	0xB10A
b01.11	AI2 Lower Limit	0.00~b01.13	1.00V		○	0xB10B
b01.12	Corresponding Setting of AI2 Lower Limit	-100.0~200.0	0.0%		○	0xB10C
	AI2 Temperature Lower Limit		0.0℃			
b01.13	AI2 Higher	b01.11	5.00V		○	0xB10D

Function Code	Name	Setting Range	Factory Setting	Description	R/W	Address
	Limit	~10.00		◆Corresponding relationship of transducer parameter setting of “Constant Temperature” and “Constant differential Temperature” control mode:		
b01.14	Corresponding Setting of AI2 Higher Limit	-100.0~200.0	100.0%		○	0xB10E
	AI2 Temperature Higher Limit		100.0℃			
b01.15	AI2 Filtering Time	0.00~10.00	0.10s		○	0xB10F
b01.16	Restart After Power-on	0~1	1	0: Invalid; 1: Valid	◎	0xB110
			0			
			1			
			0			
b01.17	Linkage Mode	0~4	1	0: Synchronous; 1: Master-slave; 2: Big-small pump combination; 3: One duty one standby; 4: One VFD drive two pumps (It needs to be used with One VFD drive two pumps boxes) Note: when b01.17 was set to 4, the following parameters will be set automatically. b01.09 is 0 (Independent Start and Stop Forbidden), b05.02 is 5 (One VFD drives two pump fault input), b05.12 is 1 (S4 terminal control), b06.03 is 10 (Relay 1 used for variable frequency pump control), b06.10 is 11 (Relay 2 used for power frequency pump control).	◎	0xB111
b01.18	Control Mode	0~3	0	0: Constant Pressure; 1: Constant Differential Pressure; 2: Constant Temperature; 4: Constant Differential Temperature	◎	0xB112
b01.19	Independent Start and Stop Control	0~1	0	Only be enabled when b05.02 =2 and b01.17≠4 0: Invalid (Start and stop is controlled by the system after being put into the system) 1: Valid (Start and stop is controlled by the inverter, which can be started and stopped by the panel or S4 terminal)	◎	0xB113
b01.20	One VFD drive two pumps mode	0~1	1	0: Fixed variable frequency pump 1: Rotate variable frequency pump When enabled, the alternate mode is	◎	0xB114

Function Code	Name	Setting Range	Factory Setting	Description	R/W	Address
				determined by b05.11, and the alternate time is set by b05.10. Note: After the alternate time reaches, when the sleep function is enabled, the system will automatically complete the alternate while sleeping. When the sleep function is not enabled, the system will complete the alternating at the lower limit of output frequency.		
b01.21	Add Power Frequency Pump Pressure Bias	0.0~b00.01	0.5bar	Bias Value of Setting Pressure /Setting Differential Pressure /Setting Temperature /Setting Differential Temperature subtract Feedback Pressure /Feedback Differential Pressure /Feedback Temperature /Feedback Differential Temperature	○	0xB115
	Add Power Frequency Pump Differential Pressure Bias		0.5bar			
	Add Power Frequency Pump Temperature Bias		5°C			
	Add Power Frequency Pump Differential Temperature Bias		5°C			
b01.22	Add Power Frequency Pump Delay Time	0.0~3600.0	10.0s	When Variable Frequency Pump reach Upper Limit Frequency, if the difference value of Setting Pressure /Setting Differential Pressure /Setting Temperature /Setting Differential Temperature subtract Feedback Pressure /Feedback Differential Pressure /Feedback Temperature /Feedback Differential Temperature is higher than or equals to b01.21, after b01.22 delay time, Power Frequency Pump would be in operation.	○	0xB116
b01.23	Subtract Power Frequency Pump Pressure Bias	0.0~b00.01	0.5bar	Bias Value of Feedback Pressure /Feedback Differential Pressure/Feedback Temperature /Feedback Differential Temperature subtract Setting Pressure /Setting Differential Pressure /Setting Temperature /Setting Differential	○	0xB117
	Subtract Power Frequency Pump Differential Pressure Bias		0.5bar			

Function Code	Name	Setting Range	Factory Setting	Description	R/W	Address
	Subtract Power Frequency Pump Temperature Bias		5.0°C	Temperature		
	Subtract Power Frequency Pump Differential Temperature Bias		5.0°C			
b01.24	Subtract Power Frequency Pump Delay Time	0.0~3600.0	5.0s	When Variable Frequency Pump reach Lower Limit Frequency, if the difference value of Feedback Pressure /Feedback Differential Pressure /Feedback Temperature /Feedback Differential Temperature subtract Setting Pressure /Setting Differential Pressure /Setting Temperature /Setting Differential Temperature is higher than or equals to b01.23, after b01.24 delay time, Power Frequency Pump would be out of operation.	○	0xB118
b01.25	Subtract Power Frequency Pump Ultimate Pressure Bias	0.0~b00.01	1.0bar	When Variable Frequency Pump reach Lower Limit Frequency, if the difference value of Feedback Pressure /Feedback Differential Pressure /Feedback Temperature /Feedback Differential Temperature subtract Setting Pressure /Setting Differential Pressure /Setting Temperature /Setting Differential Temperature is higher than or equals to b01.25, Power Frequency Pump would be out of operation immediately	○	0xB119
	Subtract Power Frequency Pump Ultimate Differential Pressure Bias		1.0bar			
	Subtract Power Frequency Pump Ultimate Temperature Bias		10.0°C			
	Subtract Power Frequency Pump Ultimate Differential Temperature Bias		10.0°C			

Function Code	Name	Setting Range	Factory Setting	Description	R/W	Address
b01.26	Subtract Power Frequency Lower Limit Frequency Retention Time	0.0~3600.0	10.0s	When the difference value of Feedback Pressure /Feedback Differential Pressure /Feedback Temperature /Feedback Differential Temperature subtract Setting Pressure /Setting Differential Pressure /Setting Temperature /Setting Differential Temperature is higher than 0 and lower than b01.23, After Variable Frequency Pump reach Lower Limit Frequency for b01.26 retention time, Power Frequency Pump would be out of operation.	○	0xB1A
b01.27	Add Variable Frequency Pump Delay Time	0.0~3600.0	3.0s	After Power Frequency Pump in operation, Variable Frequency Pump start-up delay time.	○	0xB11B
b01.28	High Temperature Alarm Value	b01.29 ~b01.09	90.0°C	Outlet side high temperature alarm preset value. When actual temperature on the outlet side is higher than this preset value, the inverter halts, alarms and displays “HT”. Constant Temperature Mode: When actual temperature on the outlet side is lower than this preset value, “HT” would be automatically cleared in 10 secs, When actual temperature on the outlet side is lower than the difference value between this preset value and bias value (b04.03), pump would restart automatically. Constant Differential Temperature Mode: When actual temperature on the outlet side is lower than this preset value, “HT” would be automatically cleared in 10 secs and pump would restart.	○	0xB11C
b01.29	Low Temperature Alarm Value	-20.0 ~b01.28	-15.0°C	Outlet side low temperature alarm preset value.	○	0xB11D
br-02 Group Application Function						
b02.00	PID Source Selection	0~1	0	0: Keypad; 1: Reserved	●	0xB200
b02.01	PID Feedback Source Selection	0~1	0	0: AI1; 1: AI2	○	0xB201
b02.02	PID Output Characteristics	0~1	0	0: Positive action; 1: Negative action	○	0xB202
			0			
			0			
			1			

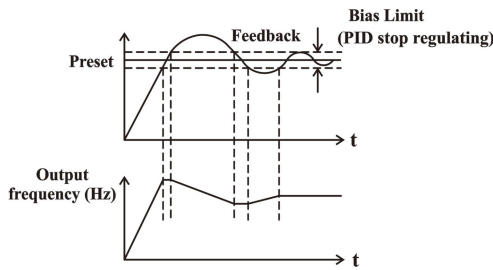
Function Code	Name	Setting Range	Factory Setting	Description	R/W	Address
b02.03	Proportional Gain (KP)	0.0~500.0	50.0	Determining the strength of PID regulation, KP is bigger, regulation is stronger, but fluctuate easier too.	○	0xB203
b02.04	Integral Coefficient (KI)	00.01~10.00	2.00	Bias between the feedback and the given, determining the speed of regulation, KI is smaller, regulation is stronger (faster).	○	0xB204
b02.05	Derivative Coefficient (KD)	0.000 ~10.000	0.000	Variable ratio between the feedback and the given, KD is bigger, regulation is stronger. Be cautious use, for differential regulation amplifies interference of system.	○	0xB205
b02.06	Reserved				—	—
b02.07	PID Control Bias Limit	0.0~100.0	0.0%	<p>Max. Bias of PID output value corresponding to closed loop given value:</p>  <p>Figure 6.2.1 PID control curve Corresponding System Diagram of Max. Limit and Output Frequency. Properly set the value can regulate the accuracy and stability of PID system.</p>	○	0xB207
b02.08	AI1 Feedback Lost Detecting Value	0.0~100.0	1.0%	Transducer fault detecting setting value, which corresponds to full range (100%).	○	0xB208
b02.09	AI2 Feedback Lost Detecting Value	0.0~100.0	0.0%	When the feedback disconnection time exceeds open circuit detection time, it is deemed as malfunction by transducer, the system will report corresponding transducer fault (AI1: E022, AI2:E033).	○	0xB209
			1.0%			
			0.0%			
			1.0%			
b02.10	Feedback Lost Detecting time	0.0~3600.0	1.0s		○	0xB20A
br-03 Group Application Function						
b03.00	Communication Address (RS585A)	0~5	0	0: Master controller; 1~5: Slave controller	◎	0xB300
b03.01	Baud Rate Selection (RS585A)	0~5	5	Data of master and slave comes into the rate. 0: 1200BPS; 1: 2400BPS; 2: 4800BPS; 3: 9600BPS; 4: 19200BPS; 5: 38400BPS	○	0xB301
b03.02	Communication Address	0~3	3	0: Non parity (8-N-2); 1: Even parity (8-E-1);	○	0xB302

Function Code	Name	Setting Range	Factory Setting	Description	R/W	Address
	(RS585A)			2: Odd parity (8-O-1); 3: Non parity (8-N-1)		
b03.03	Communication Delay Time (RS585A)	0~200	2ms	Interval of data responding.	○	0xB303
b03.04	Reserved				—	—
b03.05	Communication Error (RS585A)	0~1	0	0: Halt and alarm 1: Don't alarm and continue	○	0xB305
b03.06	Communication Response Action (RS585A)	0~1	0	0: Responding to write operation 1: Non-responding to writer operation	○	0xB306
b03.07	Data Transmission Time Interval (RS585A)	0.05~2.00	0.10s	Ensure the effects of data transmission, long-time setting will slow down data transmission and short-time setting will easily make mistakes.	○	0xB307
b03.08	Slave Quantity (RS585A)	0~5	0	The quantity for slave pump except for master pump. 0: None (Solo Mode)	◎	0xB308
b03.09	Fault Shift (RS585A)	0~2	2	Transducer fault is shifted from Master to Slave, the setting need to be coordinated with Master and Slave, When adjust parameters, firstly must adjust the master and then the auxiliary. ●Invalid: Factory setting: 2 ●Valid: Master set as 0; Salve 1 set as 1. Remarks: Fault shift demands the salve 1 to be connected with a backup transducer.	○	0xB309
b03.10	Communication Address (RS485B)	0~250	1	1~250, 0 broadcast address	○	0xB30A
b03.11	Baud Rate Selection (RS485B)	0~5	3	Communication data transmission rate 0: 1200BPS; 1: 2400BPS; 2: 4800BPS; 3: 9600BPS; 4: 19200BPS; 5: 38400BPS	○	0xB30B
b03.12	Data Format (RS485B)	0~3	3	0: Non parity (8-N-2); 1: Even parity (8-E-1); 2: Odd parity (8-O-1); 3: Non parity (8-N-1)	○	0xB30C
b03.13	Comm Delay Time (RS485B)	0~200	2ms	Interval of data responding.	○	0xB30D
b03.14	Comm Timeout Delay (RS485B)	0.0~100.0	0.0s	It will alarm after timeout detection when communication line disconnected, the controller halts, alarms and displays E016. 0: Invalid.	○	0xB30E

Function Code	Name	Setting Range	Factory Setting	Description	R/W	Address
b03.15	Communication protocol selection (RS485B)	0~1	0	0: MODBUS RTU; 1: Reserved	●	0xB30F
br-04 Group Application Function						
b04.00	Sleeping Function	0~1	1	No consuming auto stop. 0: Invalid; 1: Valid.	○	0xB400
			0			
			0			
			0			
b04.01	Sleeping Waiting Time	0.0~300.0	5.0s	No consuming to enter sleep. Unit: Seconds.	○	0xB401
b04.02	Sleeping Detection Coefficient	0~1000	150	Used for system sleep detection.	○	0xB402
			150			
			000			
			000			
b04.03	Wake-up Bias	0.0~20.0	0.5bar	During sleeping the wake-up pressure or differential pressure or temperature or differential temperature bias, e.g. the setting value (L) = 3.0bar, bias (b04.03) = 0.5bar, P<L-0.5=2.5bar, the pump will restart again.	○	0xB403
			0.3bar			
			5.0°C			
			3.0°C			
b04.04	Sleeping Bias	0.00~1.00	0.10bar	The pressure (or differential pressure or temperature or differential temperature) fluctuation which allows sleeping.	○	0xB404
			1.00°C			
b04.05	Sleep Test Cycle	0~3600.0	20.0s	Sleeping testing cycle.	○	0xB405
b04.06	Wake-up Delay Time	0~36000	0s	Wake-up delay time after sleeping	○	0xB406
br-05 Group Application Function						
b05.00	Water Level Control (S3Terminal Control)	0~2	2	Water level switch style, this parameter is invalid if the b05.02 is set to 4. 0: Invalid; 1: NC; 2: NO	○	0xB500
b05.01	Low Lever Restart Delay Time	0~300	1min	Delay time of restart after water level switch recover.	○	0xB501
b05.02	Terminal Control	0~5	2	0: Invalid 1: Electric contact control (invalid for one duty and one standby mode) <u>S1-COM</u> on: Frequency rise <u>S2-COM</u> on: Frequency drop 2: Manual/auto control <u>S2-COM</u> off: Auto control <u>S2-COM</u> on: Manual control 3: Terminal run/stop	◎	0xB502

Function Code	Name	Setting Range	Factory Setting	Description	R/W	Address
				<p>S1-COMon: Run S1-COMoff: Stop S2-COMoff: Auto control S2-COMon: Manual control</p> <p>4: Water Pool control (Water level auto control, b05.12≠1) S1 Lower pool low level, S2 Lower pool high level, S3 Upper pool low level, S4 Upper pool high level. S1-COMoff: Water shortage protection, stop pump. S2-COMoff: Star-up delay, avoid frequent start. S3-COMoff: Water supplement. S4-COMon: Pump stops when upper pool overflow (full) When S1-COM is off, lower pool water is in shortage, pump is running with zero or freeze-proofing frequency until S1-COM switch on, when S2-COM is on, can just supply water; when S4-COM is on, upper pool overflow (be full), pump is running with zero frequency or freeze-proofing frequency until S4-COM switch off, when S3-COM is off, can just supply water; Alternating water supply on each pump, it will alternately start to the next next pump after stopping pump (pump stops when water shortage or overflow).</p> <p>5: One VFD drive two pumps failure input: S1-COMon: #1 pump failure (Variable Frequency Pump) S2-COMon: #2 pump failure (Power Frequency Pump)</p>		
b05.03	Acceleration Time	0.1s~3600.0s	Model Set	The setting time from zero to max. frequency	○	0xB503
b05.04	Deceleration Time	0.1s~3600.0s	Model Set	The setting time from max. frequency to zero	○	0xB504
b05.05	Maximum Output Frequency	50.00 ~600.00	50.00Hz	Determine the Acceleration /Deceleration rate.	◎	0xB505
b05.06	Upper limit of Output	b05.07 ~b05.05	50.00Hz	Maximum running frequency	○	0xB506

Function Code	Name	Setting Range	Factory Setting	Description	R/W	Address
	Frequency					
b05.07	Lower Limit of Output Frequency	00.00 ~b05.06	20.00Hz	The minimum running frequency of pump.	○	0xB507
b05.08	Carrier Frequency	1.0kHz ~15.0kHz	Model Set	Used to ameliorate the noise of motor and controller's interference to the surroundings. A high carrier frequency makes a low motor noise, but leads to a big temperature rise and interference. Should not be altered if unnecessary.	◎	0xB508
b05.09	Low Pressure (LP) Restart Delay Time	0~36000	10min	In case of low pressure (LP) or low temperature (LT), when b05.09≠0, the controller restarts to work according to the setting time automatically, without manual restart. b05.09=0, restart invalid.	○	0xB509
	Low Temperature (LT) Restart Delay Time					
b05.10	Alternating Time	0.00~300.00	8.00h	In order to balance and prolong the pump service life to set the parameter, in operation, the master and the auxiliary pumps take turns to act as the host machine according to the set time, the unit is hour. 0.00 H is not alternate.	○	0xB50A
b05.11	Alternating Mode	0~1	0	0: Alternate according to alternating time or sleeping wake-up 1: Only alternate according to alternating time	○	0xB50B
b05.12	S4 Terminal Control	0~3	0	0: Invalid; 1: Start-stop; 2: Forward and reverse switching; 3: Analog signal source (AI1, AI2) switching	◎	0xB50C
br-06 Group Application Function						
b06.00	Running Status Display Selection	0x0000~ 0xFFFF	0x041F	Bit0: Operational frequency Bit1: The actual pressure of pump outlet /The actual differential pressure /The actual temperature of pump outlet /The actual differential temperature Bit2: The setting pressure of pump outlet /The setting differential pressure /The setting temperature of pump outlet /The setting differential temperature Bit3: Output current Bit4: DC bus voltage Bit5: Output voltage Bit6: Present time	○	0xB600

Function Code	Name	Setting Range	Factory Setting	Description	R/W	Address
				Bit7: The actual pressure of pump inlet /The actual temperature of pump outlet Bit8: Input terminal status Bit9: Output current and the actual pressure of pump outlet /Output current and the actual differential pressure /Output current and the actual temperature of pump outlet /Output current and the actual differential temperature Bit10: The setting pressure of pump outlet and the actual pressure of pump outlet /The setting differential pressure and the actual differential pressure /The setting temperature of pump outlet and the actual temperature of pump outlet /The setting differential temperature and the actual differential temperature Note: Under manual model only display “operational frequency”, “output current” and “DC bus voltage”		
b06.01	Stop Status Display Selection	0x0000~0xFFFF	0x020F	Bit0: The setting pressure of pump outlet /The setting differential pressure /The setting temperature of pump outlet /The setting differential temperature Bit1: The actual pressure of pump outlet /The actual differential pressure /The actual temperature of pump outlet /The actual differential temperature Bit2: Giver frequency Bit3: DC bus voltage Bit4: Input terminal status Bit5: Output terminal status Bit6: AI1 input voltage Bit7: The actual pressure of pump inlet /The actual temperature of pump outlet Bit8: Present time Bit9: The setting pressure of pump outlet and the actual pressure of pump outlet /The setting differential pressure and the actual differential pressure /The setting temperature of pump outlet and the actual temperature of pump outlet /The setting differential temperature and the actual differential temperature	○	0xB601

Function Code	Name	Setting Range	Factory Setting	Description	R/W	Address
				Note: Under manual model only display “giver frequency”, “output current” and “DC bus voltage”		
b06.02	Keypad Display	0~3	3	0: External keypad prior enable 1: Both display enable, only external keypad control; 2: Both display enable, only on board keypad control; 3: Both display enable and keypad control	●	0xB602
b06.03	Relay 1 Output Selection	0~11	0	0: Error or external fault; 1: Forward running (including zero-speed running); 2: Upper limit frequency reaching; 3: Stop status; 4: Lower limit frequency reaching; 5: The frequency is not equal to zero; 6: Actual pressure on the outlet side reaching high water pressure alarm value; 7: Actual pressure on the outlet side decreases to low water pressure alarm value; 8: Actual temperature on the outlet side reaching high temperature alarm value; 9: Actual temperature on the outlet side decreases to low temperature alarm value; 10: One VFD drive two pumps, used for variable frequency pump control 11: One VFD drive two pumps, used for power frequency pump control	○	0xB603
b06.04	Third Latest Fault Type				●	0xB604
b06.05	Second Latest Fault Type		Read Only	Refers to chapter 9. Fault and Trouble Shooting	●	0xB605
b06.06	Latest Fault Type				●	0xB606
b06.07	Parameters Storage Condition	0~2	0	0: Power-off storage 1: Power-off default storage 2: Invalid	○	0xB607
b06.08	Accumulated Running Time	0h~65535h	Read Only	Display accumulated running time	●	0xB608
b06.09	Set the Password of b00.00	0~65535	65535	Password set prevent user from modifying the parameters randomly, avoiding running abnormally and damages.	—	—
b06.10	Relay 2 Output	0~11	1	0: Error or external fault;	○	0xB60A

Function Code	Name	Setting Range	Factory Setting	Description	R/W	Address
	Selection			1: Forward running (including zero-speed running); 2: Upper limit frequency reaching; 3: Stop status; 4: Lower limit frequency reaching; 5: The frequency is not equal to zero; 6: Actual pressure on the outlet side reaching high water pressure alarm value; 7: Actual pressure on the outlet side decreases to low water pressure alarm value; 8: Actual temperature on the outlet side reaching high temperature alarm value; 9: Actual temperature on the outlet side decreases to low temperature alarm value; 10: One VFD drive two pumps, used for variable frequency pump control 11: One VFD drive two pumps, used for power frequency pump control		
b06.11	Relay output valid status selection	00~11	00	0: Positive logic 1: Negative logic Units: relay 1 Tens: relay 2	○	0xB60B
b06.12 ~b06.16	Reserved					
br-07 Group Application Function						
b07.00	Lower Limit of Inlet Pressure	0.0~100.0	0.0bar	1.This parameter is always valid. 2. When the detected inlet pressure or inlet temperature is lower than this value, the pump stops running and reports a fault. "LP2" or "LT2" is displayed on LED. 3. Do not modify this parameter if the lower limit of inlet side pressure is not required in practical application. 4. When the lower limit of inlet side temperature is not required in practical application, the sensor open-circuit detection (b02.09 =0.0) should be canceled	○	0xB700
	Lower Limit of Inlet Temperature	-15.0~200.0	-15.0℃			
b07.01	Restore Defaults	0~2	0	0: No action 1: Set to default 2: Clear error records	◎	0xB701
b07.02	Day-part Function Selection	0~3	0	Day-part different pressure /differential pressure /temperature /differential temperature control	◎	0xB702

Function Code	Name	Setting Range	Factory Setting	Description	R/W	Address
				0: Invalid; 1: Day-part A; 2: Day-part A and B; 3: Day-part A, B, C		
b07.03	Day-part A Starting Time	00-00~23-59	00-00	<p>◆Setting starting time and finishing time to 00-00 does not enable this function.</p> <p>◆Finishing time should be no less than starting time.</p> <p>◆Running pressure /differential pressure /temperature /differential temperature is equivalent to setting pressure /differential pressure /temperature /differential of day-part.</p> <p>◆Once actual inlet side pressure /temperature lower than inlet pressure /temperature lower limit pressure /temperature, the pump stops running and reports a fault. “LP2”/“LT2” is displayed on LED.</p> <p>◆Please set the lower limit as 0.0 if the lower limit of inlet side pressure is not required in practical application.</p> <p>◆When the lower limit of inlet side temperature is not required in practical application, the sensor open-circuit detection (B02.09 =0.0) should be canceled.</p>	☉	0xB703
b07.04	Day-part A Pressure Setting	-15.0 ~b01.00-1.0	3.0bar		<p>○ 0xB704</p>	
	Day-part A Differential Pressure Setting	0.0 ~b01.00-1.0	0.5bar			
	Day-part A Temperature Setting	-15.0 ~b01.28-10.0	30.0℃			
	Day-part A Differential Temperature Setting		5.0℃			
b07.05	Day-part A Finishing Time	00-00~23-59	00-00		☉	0xB705
b07.06	Lower Limit of Inlet side Pressure of Day-part A	0.0~100.0	2.0bar		<p>○ 0xB706</p>	
	Lower Limit of Inlet side Temperature of Day-part A	-15.0~200.0	-15.0℃			
b07.07	Day-part B Starting Time	00-00~23-59	00-00		☉	0xB707
b07.08	Day-part B Pressure Setting	-15.0 ~b01.00-1.0	3.0bar		<p>○ 0xB708</p>	
	Day-part B Differential Pressure Setting	0.0 ~b01.00-1.0	0.5bar			
	Day-part B Temperature Setting	-15.0 ~b01.28-10.0	30.0℃			
	Day-part B Differential Temperature Setting		5.0℃			
b07.09	Day-part B	00-00~23-59	00-00	☉	0xB709	

Function Code	Name	Setting Range	Factory Setting	Description	R/W	Address
	Finishing Time					
b07.10	Lower Limit of Inlet side Pressure of Day-part B	0.0~100.0	2.0bar		○	0xB70A
	Lower Limit of Inlet side Temperature of Day-part B	-15.0~200.0	-15.0℃			
b07.11	Day-part C Starting Time	00-00~23-59	00-00		◎	0xB70B
b07.12	Day-part C Pressure Setting	-15.0 ~b01.00-1.0	3.0bar			
	Day-part C Differential Pressure Setting	0.0 ~b01.00-1.0	0.5bar			
	Day-part C Temperature Setting		30.0℃		○	0xB70C
	Day-part C Differential Temperature Setting	-15.0 ~b01.28-10.0	5.0℃			
b07.13	Day-part C Finishing Time	00-00~23-59	00-00		◎	0xB70D
b07.14	Lower Limit of Inlet side Pressure of Day-part C	0.0~100.0	2.0bar		○	0xB70E
	Lower Limit of Inlet side Temperature of Day-part C	-15.0~200.0	-15.0℃			
b07.15	One Duty One Standby Operation Mode Select	0~3	0	Day-Part different Master Pump Operating: 0: Invalid 1: Day-part A 2: Day-part A and B 3: Day-part A, B and C	◎	0xB70F
b07.16	Master Starting Time Day-part A	00-00~23-59	00-00	Only limited to one duty one standby pump linkage system (b01.17=3);	◎	0xB710
b07.17	Master Finishing Time Day-part A	00-00~23-59	00-00	◆ When b07.15≠0, No.0 pump as the master pump to operate within setting time, other	◎	0xB711
b07.18	Master Starting	00-00~23-59	00-00	time No.1 pump as the master pump to	◎	0xB712

Function Code	Name	Setting Range	Factory Setting	Description	R/W	Address
	Time Day-part B			operate;		
b07.19	Master Finishing Time Day-part B	00-00~23-59	00-00	◆If fault shift happen,the No.1 pump change into new master pump No.0 and directly	⊙	0xB713
b07.20	Master Starting Time Day-part C	00-00~23-59	00-00	run as master pump;	⊙	0xB714
b07.21	Master Finishing Time Day-part C	00-00~23-59	00-00	◆When b07.15=0, the master pump will operate according to setting alternating time	⊙	0xB715
b07.22	Password of Group Br08	0~65535	00000	0~65535	—	—
br-08 Group Application Function						
b08.00	Motor Rated Power	0.1kW ~350.0kW	Model Set	Depends on model, setting parameters according to nameplate of motor	⊙	0xB800
b08.01	Motor Rated Frequency	0.01~b05.05	50.00Hz		⊙	0xB801
b08.02	Motor Rated Speed	1RPM ~36000RPM	Model Set		⊙	0xB802
b08.03	Motor Rated Voltage	1V~460V			⊙	0xB803
b08.04	Motor Rated Current	P≤55kW: 0.01A ~655.35A P>55kW: 0.1A ~6553.5A			⊙	0xB804
b08.05	Reserved					
b08.06	Delay time when adding pump	0.1~3600.0	0.5s	After pump operating with full frequency, delay the time of b08.07 , the next pump will operate.	○	0xB806
b08.07	Set the Password of b07.22	0~65535	65535	Set the Password of b07.22	—	—
b08.08	Password of Factory Parameters	0~65535	xxxxxx	Don't try to enter or will cause abnormal operation and damages.	—	—

In order to ensure the pumps running safety, please enter rated value correctly from motor nameplate. **Attention: Bold function code won't restore the default setting even if resetting.**

7. QUICK DEBUG of PARAMETER SETTING

Please follow the below steps to complete debugging

Step1: Wiring

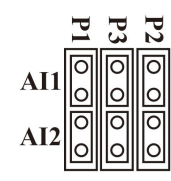
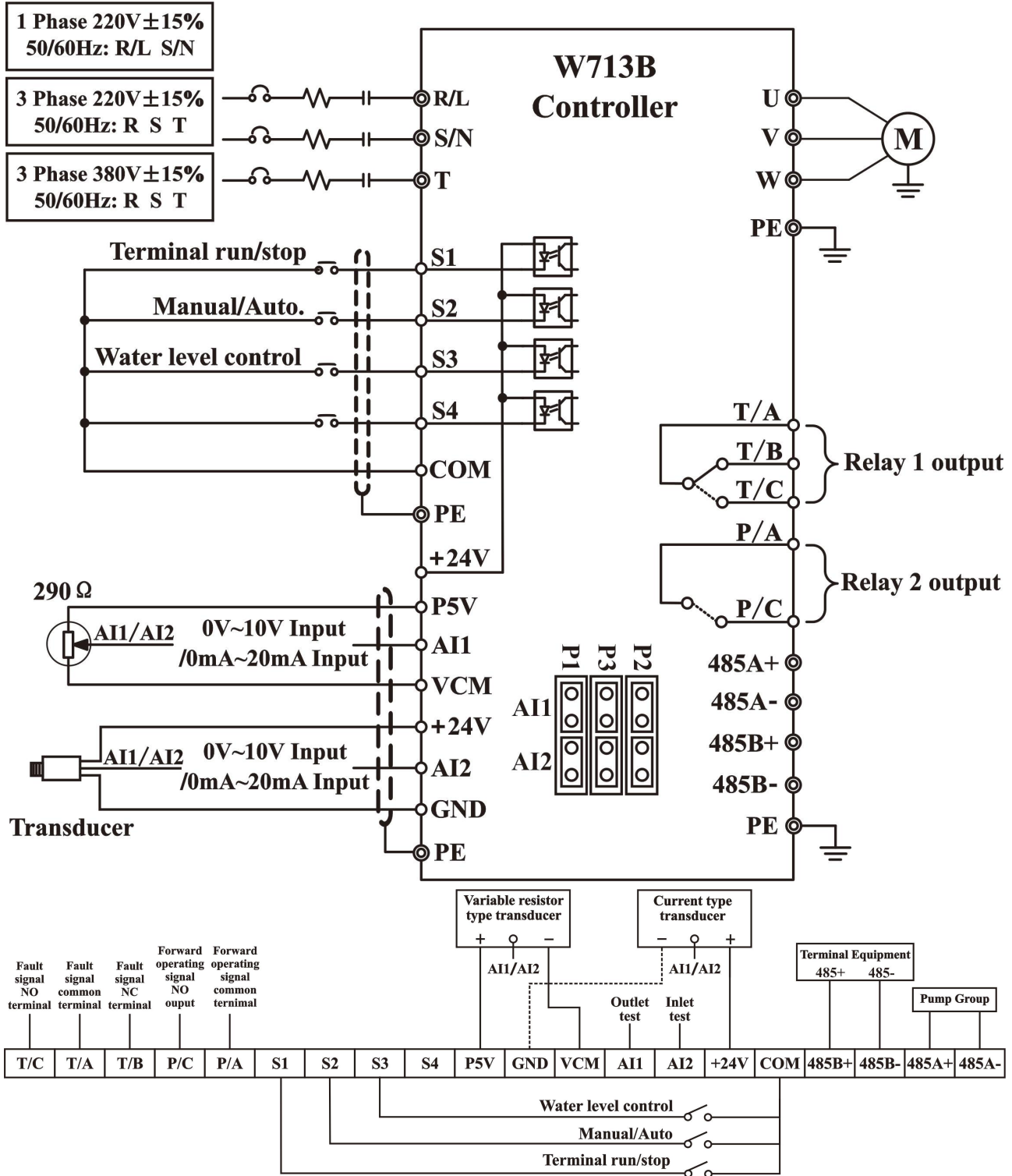

- P1:** Transducer selection switch, plug in the short circuit cap as current signal, otherwise voltage signal.
- P2:** 485A communication terminal resistance selection, plug in the short circuit cap to connect terminal resistor and otherwise. Note that plug the short-circuit caps on the first and tail two when multiple pumps are online. that for multi-pump, only open toggle switch of the first pump and last pump.
- P3:** 485B communication terminal resistance selection, plug in the short circuit cap to connect terminal resistor and otherwise. Note that plug the short-circuit caps on the first and tail two when multiple pumps are online. that for multi-pump, only open toggle switch of the first pump and last pump.

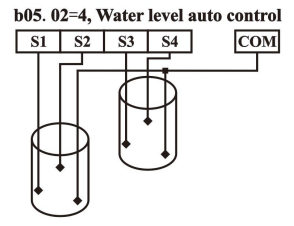

Figure 7.1.1 Single pump water supply system wiring

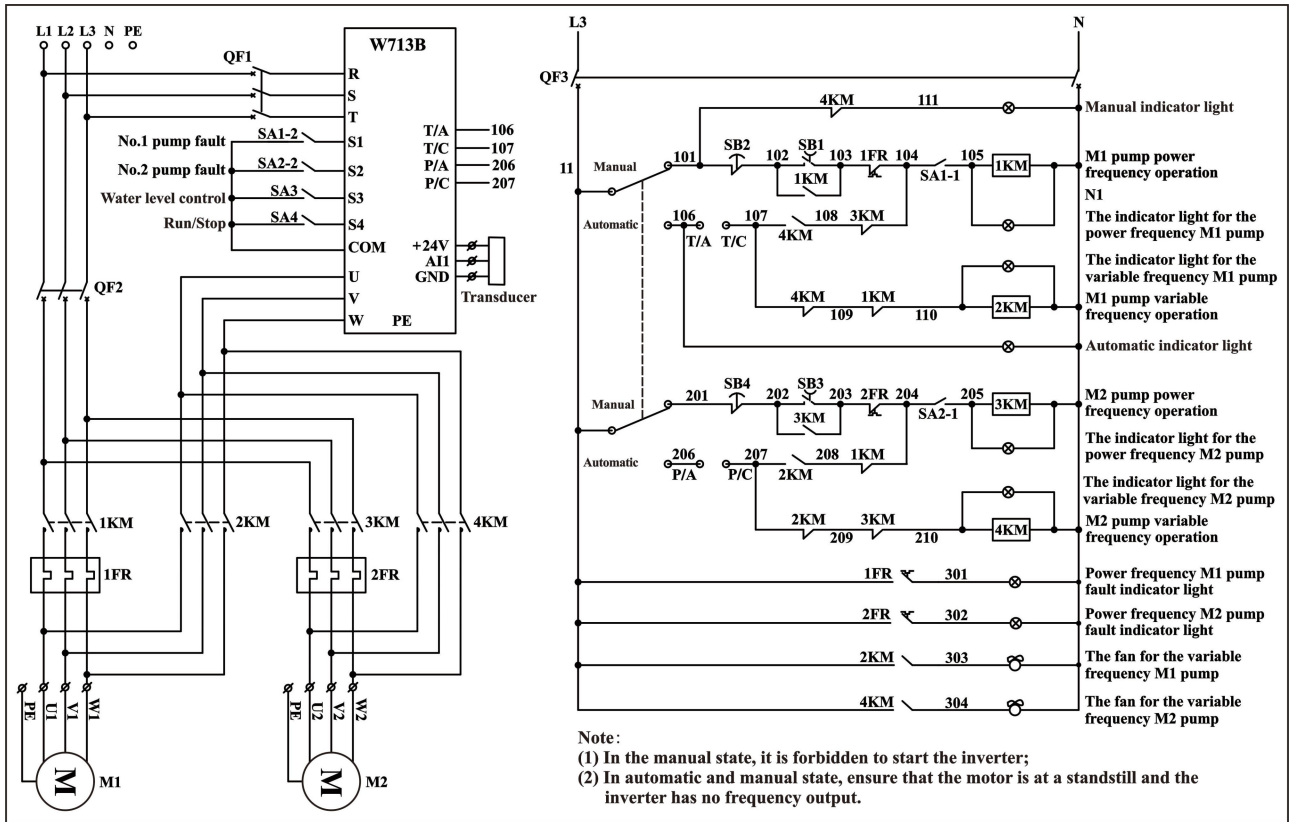

Figure 7.1.2 0.75kW~7.5kW One VFD drive two pumps wiring

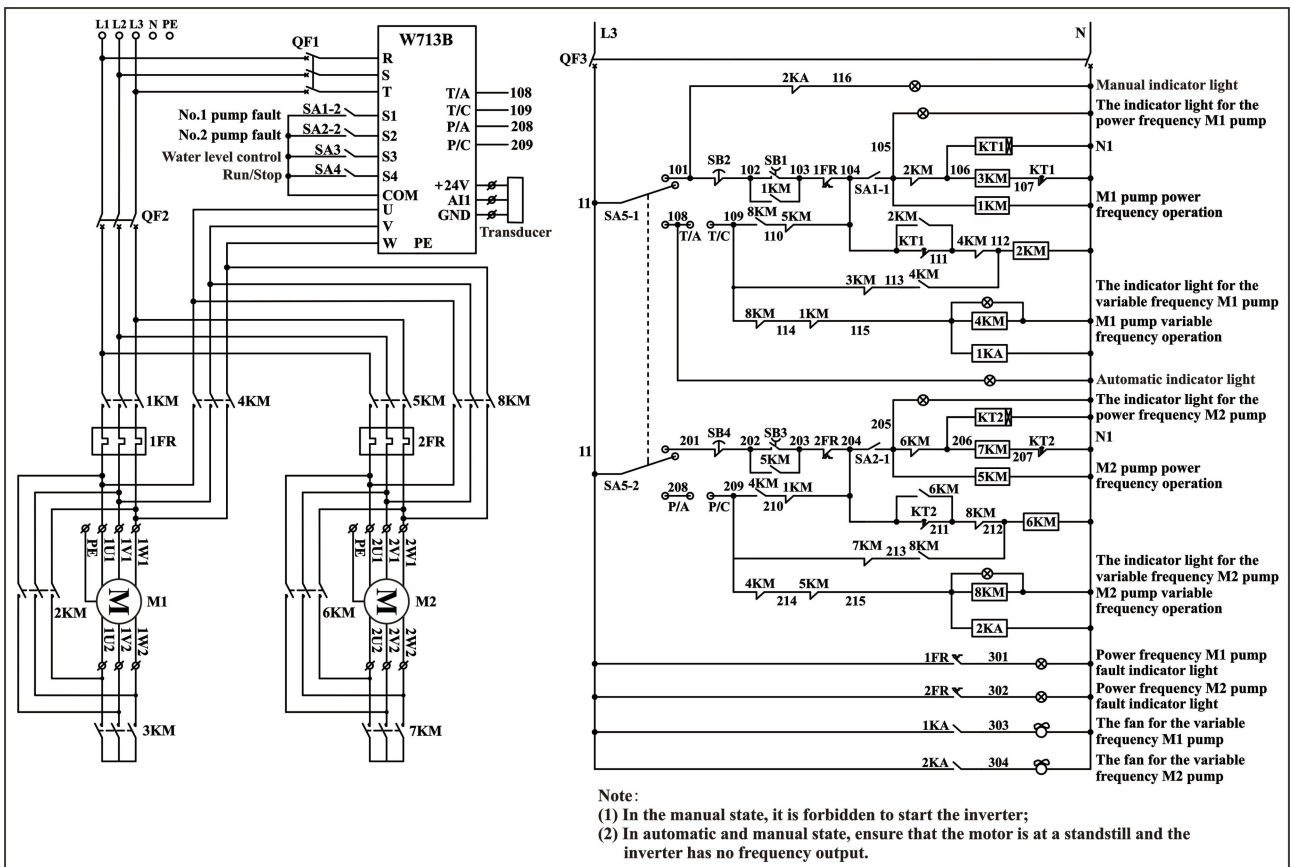

Figure 7.1.3 11kW and above One VFD drive two pumps wiring

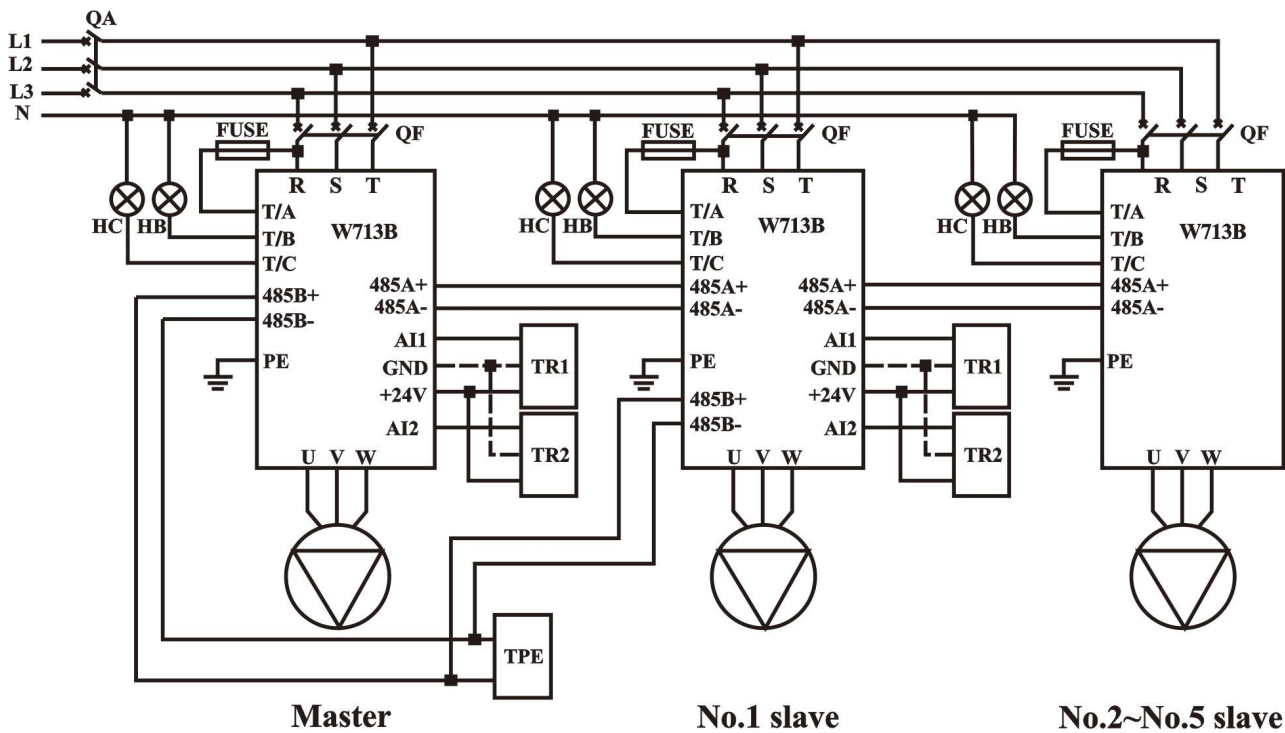
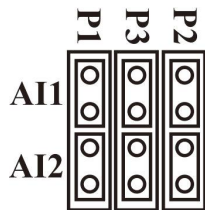

Figure 7.1.4 Multi-Pump water supply system wiring

NOTICE:

- Pressure Transducer in the figure 7.1.4 adopt two-wire current (0~20mA input) type, if adopt voltage type (1~5V input), please refer to wiring of figure 7.1.1.
- Terminal Manual/Auto Control: Just add external control switch to S2-COM, Generally Manual/Auto control is only applied to auxiliary pump.
- Control 5 auxiliaries at most, up to 6 pump linkage work.
- Use a multi-core shielded or twisted-pair cable to connect the control terminal. When the shielded cable (the end close to the inverter) is used, it should be connected to the ground terminal PE of the inverter.
- When wiring, the control cable should be more than 20cm away from the main circuit and strong electric wires (including power wires, motor wires, relays, contactor connection wires, etc.), and avoid parallel placement. It is recommended to use vertical wiring, in order to prevent the mis-operation of the inverter caused by external interference.



- Plug in jumper cap on P2 to connect to terminal resistance,

Noted that for multi-pump linkage, only need to plug in jumper cap on the first pump and the last pump.

Step2: Modify b08.00~b08.04 parameters according to motor nameplate

b08.00: Rated power of motor (cannot exceed the power labeled on inverter nameplate)

b08.01: Rated frequency of motor (Normally 50Hz/60Hz)

b08.02: Rated RPM of motor

b08.03: Rated Voltage of motor

b08.04: Rated current of motor (Cannot exceed the output current labeled on inverter nameplate)

Step3: Confirmation of the pump operating direction

A short trial run to see if the pump's running rotation is correctly. The pump steering can be changed in the following two ways:

(1) Power off inverter until its LED display extinguish, switch over any two output wires of U, V, W

(2) Stop inverter, modify parameter b00.02

Step4: Setting control mode and linkage mode

b01.18: Set this parameter based on the required control mode. b01.18=0 (constant pressure), b01.18=1 (constant differential pressure), b01.18=2 (constant temperature), b01.18=3 (constant differential temperature)

b01.17: Set this parameter based on the required linkage mode. b01.17=0 (synchronous), b01.17=1 (master-slave), b01.17=2 (big-small pump), b01.17=3 (one duty one standby), b01.17=4 (one VFD drive two pumps)

Step5: Setting transducer measuring range, feedback type

(1) Pressure transducer setting, Set "b01.05" according to the maximum range labeled on pressure transducer.

(2) Temperature transducer setting

b01.07: AI1 temperature lower limit (outlet), set this paramete according to the minimum value of the labeled on temperature transducer.

b01.09: AI1 temperature Higher limit (outlet), set this paramete according to the maximum value of the labeled on temperature transducer.

b01.12: AI2 temperature lower limit (inlet), set this paramete according to the minimum value of the labeled on temperature transducer.

b01.14: AI2 temperature Higher limit (inlet), set this paramete according to the maximum value of the labeled on temperature transducer.

(3) According to the transducer feedback type, plug in the short circuit cap as current signal, otherwise for voltage signal.

Step6: Correct displayed pressure/temperature value

b01.06: AI1 input voltage lower limit (used for adjusting zero bias of transducer)

b01.08: AI1 input voltage higher limit (when display value smaller than the actual value, decrease Higher Limit; when display value greater than the actual value, increase Higher Limit)

b01.11: AI2 input voltage lower limit (used for adjusting zero bias of transducer)

b01.13: AI2 input voltage higher limit (when display value smaller than the actual value, decrease Higher Limit; when display value greater than the actual value, increase Higher Limit)

Step7: Multi-pumps quick setting

b00.07: Can quickly set parameters of multi-pumps

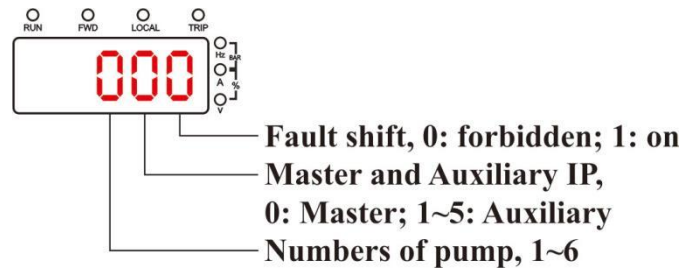

For example, when set parameters of three pump, Master b00.07=301, No.1 slave b00.07=311, No.2 slave b00.07=320

8. APPLICATION GUIDANCE

8.1 Application of Constant Pressure Water Supply

W713B product has various function, the following introduce some typical application cases of W713B and relevant parameter setting methods. In practical applications, you can reference to set.

8.1.1 Single Pump Water Supply and Parameter Setting

8.1.1.1 System Wiring

In diagram: ①W713B intelligent controller; ②Pumps group; ③Pressure tank; ④None-return valve; ⑤Pressure transducer; ⑥Water level switch (to pool); ⑦Fault indicator; ⑧Power supply indicator; ⑨Fuse; ⑩Breaker ⑪ Terminal equipment. Only wants the faults and running indication will requires ⑦⑧⑨.

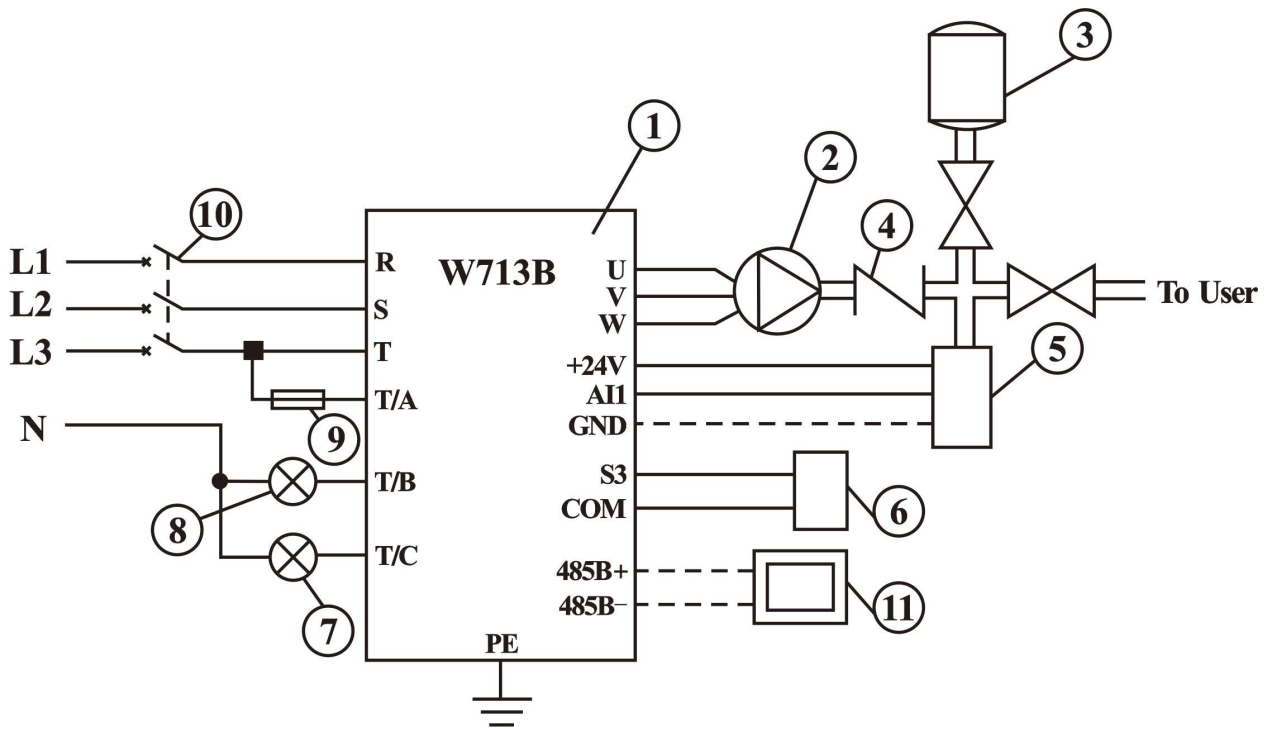

Figure 8.1.1 Single pump wiring addition failure indication

1) In the figure, we adopted the transducer is two line current type transducer of the company. Others connect refers to Figure 4.3.1;

2) The pool water should be used water level control switch. If the water pump is the pipeline booster pressure pump, it does not need the water level control switch.

8.1.1.2 System Debugging Procedure

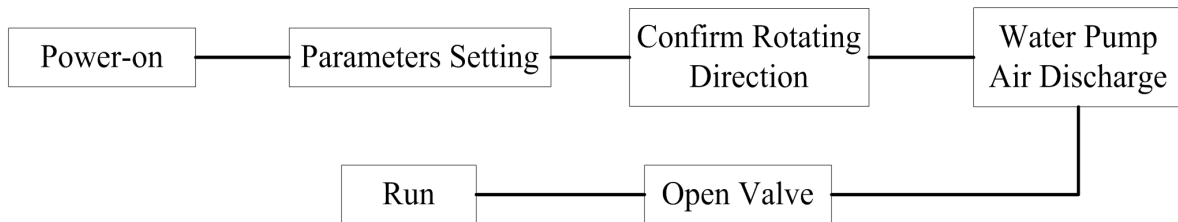

Figure 8.1.2 Debugging flow diagram

8.1.1.3 Relevant Parameter Setting

Table 8.1.1 Parameter setting of single pump constant pressure control water supply

Code	Factory Setting	Recommend	Description
b00.00	65535	65535	Password of entering parameter groups. Factory set is 65535, it can be modified by b06.09.
b08.00 ~b08.04			Ensure normal operation, must input parameter according to nameplate of motor.
b00.02	0	x	Motor rotating direction, set according to the actual motor wiring of spot. Make sure the motor is running in forward direction.
b01.18	0	0	Constant pressure
Below need to set based on working conditioning and user's requirement.			
b00.01	3.0	x.x	The pressure of water supply

Code	Factory Setting	Recommend	Description
b01.00	8.0	xx.x	High Water Pressure Alarm Value, prevent system from damage caused by high water pressure.
b01.01	0.5	x.x	Low Water Pressure Alarm Value, prevent pump from damage caused by anhydrous idling.
b01.05	10.0	xx.x	Transducer range, input the max. range of connected transducer
b01.06	1.00	x.xx	Use to transducer zero setting
b01.08	5.00	x.xx	When display smaller than gauge, decrease b01.08; When display greater than gauge, increase b01.08.
b01.16	1	x	Restart after Power-on, considering unattended management, set parameter to 1.
b05.00	0	x	Water Level Switch type, according to the using switch type 1: NC valid 2: NO valid
b05.02	2	3	<p>*Notice: Only set this parameter on apply the terminal control , simply set the master.</p> <p> S1-COMoff: stop S1-COMon: start S2-COMoff: auto mode S2-COMon: manual mode </p>
b00.03	0	1	* Anti-freezing function, valid it when the pump work under a freezing temperature.
b01.03	5.00	xx.xx	Be valid when b00.03 was set to 1, when sleep, running with the setting frequency in case of freezing. This value should be lower than the lower limited frequency (b05.07).
b02.03	50.0	xxx.x	PID parameter debugging. Increase voltage stabilization accuracy or proper regulation when Bias oversize and overwhelmed.
b02.04	2.00	x.xx	

8.1.2 Multi-pump Control

8.1.2.1 Typical System Wiring

In diagram: QA—Automatic air switch; QF—Break; FUSE—Fuse; HB—Power light; HC—Fault light; MP—Motor and pump; BQ—Water level switch; BP1—Outlet pressure transducer; BP2—Backup pressure transducer; TPE—Terminal equipment. Only wants the faults and running indication will requires the FUSE, HB, HC.

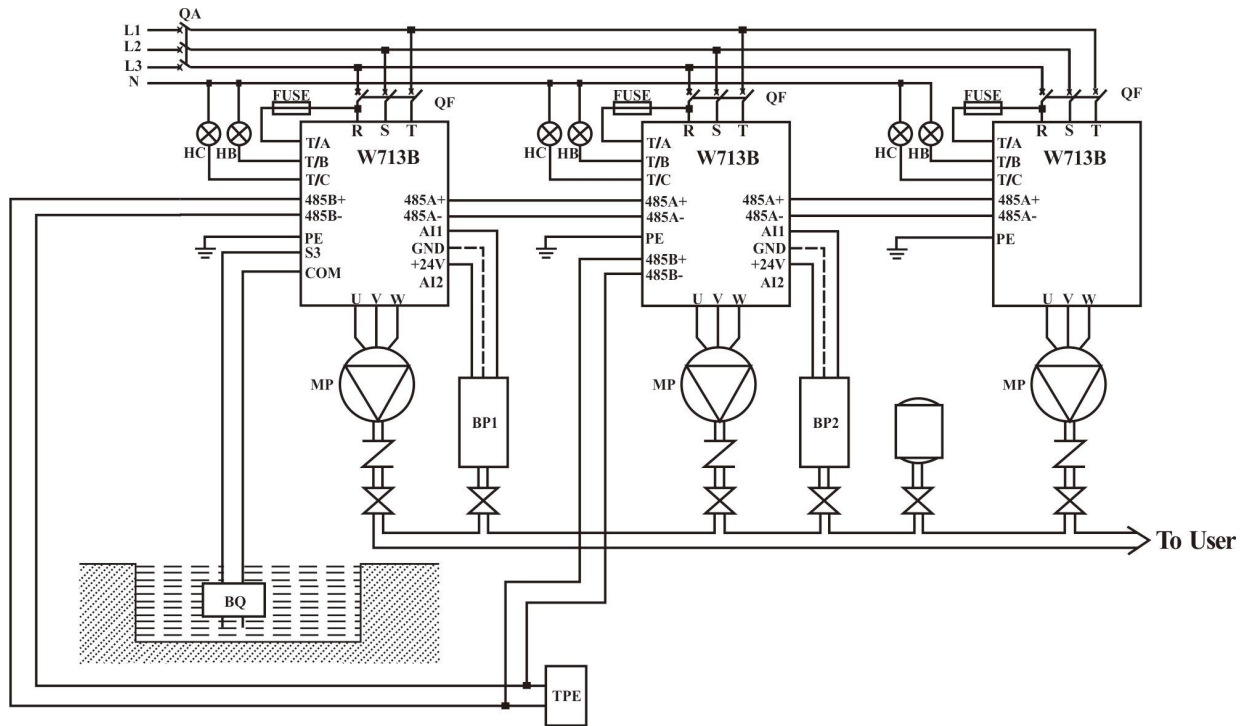



Figure 8.1.3 Multi-pump linkage constant pressure water supply wiring

8.1.2.2 Relevant Parameter Setting

Table 8.1.2 Multi-pump linkage constant pressure master setting

Code	Factory Setting	Recommend	Description
b00.00	65535	65535	Password of entering parameter groups. Factory set is 65535, it can be modified by b06.09.
b08.00 ~b08.04			Ensure normal operation, must input parameter according to nameplate of motor.
b00.02	0	x	Motor rotating direction, set according to the actual motor wiring of spot. Make sure the motor is running in forward direction.
b00.07	100	x0x	 <p>Fault shift, 0: forbidden; 1: on Master and Auxiliary IP, 0: Master; 1~5: Auxiliary Numbers of pump, 1~6</p>
b01.18	0	0	Constant pressure
Below need to set based on working conditioning and user's requirement.			
b00.01	3.0	x.x	The pressure of water supply
b01.00	8.0	xx.x	High Water Pressure Alarm Value, prevent system from damage caused by high water pressure.
b01.01	0.5	x.x	Low Water Pressure Alarm Value, prevent pump from damage caused by anhydrous idling.
b01.05	10.0	xx.x	Transducer range, input the max. range of connected transducer
b01.06	1.00	x.xx	Use to transducer zero setting
b01.08	5.00	x.xx	When display smaller than gauge, decrease b01.08; When display greater than gauge, increase b01.08.



Code	Factory Setting	Recommend	Description
b01.16	1	x	Restart after Power-on, considering unattended management, set parameter to 1.
b01.17	1	x	Linkage Mode 0: Synchronous; 1: Master-slave; 2: Big-small pump combination; 3: One duty one standby
b05.00	0	x	Water Level Switch type, according to the using switch type 1: NC valid; 2: NO valid
b05.02	2	3	*Notice: Only set this parameter on apply the terminal control , simply set the master. Terminal Start and Stop Control 
b05.10	8.00	xx.x	Alternating time, balance the service time of all pumps.
b00.03	0	1	* Anti-freezing function, valid it when the pump work under a freezing temperature.
b01.03	5.00	xx.xx	Be valid when b00.03 was set to 1, when sleep, running with the setting frequency in case of freezing. This value should be lower than the lower limited frequency (b05.07).
b02.03	50.0	xxx.x	PID parameter debugging. Increase voltage stabilization accuracy or proper regulation when Bias oversize and overwhelmed.
b02.04	2.00	x.xx	

Table 8.1.3 Multi-pump linkage constant pressure NO.1 slaves' setting

Code	Factory Setting	Recommend	Description
b00.00	65535	65535	Password of entering parameter groups. Factory set is 65535, it can be modified by b06.09.
b02.08	1.0	0.0	Auxiliary is need not to connect a transducer, this parameter should be set as 0. If you use the Fault Shift, this parameter of the backup master no need to modify.
b08.00 ~b08.04	---	---	Ensure normal operation, must input parameter according to nameplate of motor.
b00.02	0	x	Motor rotating direction, set according to the actual motor wiring of spot. Make sure the motor is running in forward direction.
b00.07	100	x1x	 <p>Fault shift, 0: forbidden; 1: on Master and Auxiliary IP, 0: Master; 1~5: Auxiliary Numbers of pump, 1~6</p>
Below need to set based on working conditioning and user's requirement.			
b01.00	8.0	xx.x	High Water Pressure Alarm Value, prevent system from damage caused by high water pressure.



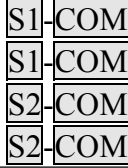

Code	Factory Setting	Recommend	Description
b01.01	0.5	x.x	Low Water Pressure Alarm Value, prevent pump from damage caused by anhydrous idling.
b01.05	10.0	xx.x	Transducer range, input the max. range of connected transducer
b01.16	1	x	Restart after Power-on, considering unattended management, set parameter to 1.
b05.00	0	x	Water Level Switch type, according to the using switch type 1: NC valid; 2: NO valid
b05.02	2	3	<p>*Notice: Only set this parameter on apply the terminal control , simply set the master.</p> <p>Terminal Start and Stop Control</p>  <p>S1-COM off: stop S1-COM on: start S2-COM off: auto mode S2-COM on: manual mode</p>
b05.10	8.00	xx.x	Alternating time, balance the service time of all pumps.
b00.03	0	1	* Anti-freezing function, valid it when the pump work under a freezing temperature.
b01.03	5.00	xx.xx	Be valid when b00.03 was set to 1, when sleep, running with the setting frequency in case of freezing. This value should be lower than the lower limited frequency (b05.07).
b02.03	50.0	xxx.x	PID parameter debugging. Increase voltage stabilization accuracy or proper regulation when Bias oversize and overwhelmed.
b02.04	2.00	x.xx	

Table 8.1.4 Multi-pump linkage constant pressure other slaves' setting

Code	Factory Setting	Recommend	Description
b00.00	65535	65535	Password of entering parameter groups. Factory set is 65535, it can be modified by b06.09.
b08.00~ b08.04			Ensure normal operation, must input parameter according to nameplate of motor.
b00.02	0	x	Motor rotating direction, set according to the actual motor wiring of spot. Make sure the motor is running in forward direction.
b00.07	100	xx0	 <p>Fault shift, 0: forbidden; 1: on Master and Auxiliary IP, 0: Master; 1~5: Auxiliary Numbers of pump, 1~6</p>
Below need to set based on working conditioning and user's requirement.			
b01.16	1	x	Restart after Power-on, considering unattended management, set parameter to 1.
b05.02	2	3	<p>*Notice: Only set this parameter on apply the terminal control , simply set the master.</p> <p>Terminal Start and Stop Control</p>

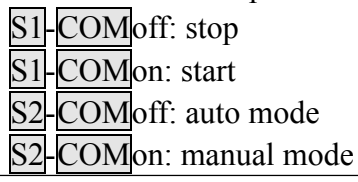
Code	Factory Setting	Recommend	Description
			S1-COM off: stop
			S1-COM on: start
			S2-COM off: auto mode
			S2-COM on: manual mode

***Tip:** After setting parameters, should press  key to make the Slave enter into remote standby status (Slave indicator power-on), then control the system start and stop via  key of the Master.

8.2 Application of Constant Differential Pressure Water Supply

W713B series product have rich functions, the typical application modes and related parameter setting methods of intelligent constant pressure differential water supply pressure for W713B series pump are introduced below, which can be set for your reference in actual application.

8.2.1 Differential Pressure Control System Introduction.

Figure8.2.1 is the schematic diagram of the central air-conditioning water circulation system. The VFD in the figure is the W713B Controller. In the application, adopt Dual-Transducers mode to get the feedbacks from inlet and outlet pressure value separately to controller's receiving port to realize constant pressure differential control.

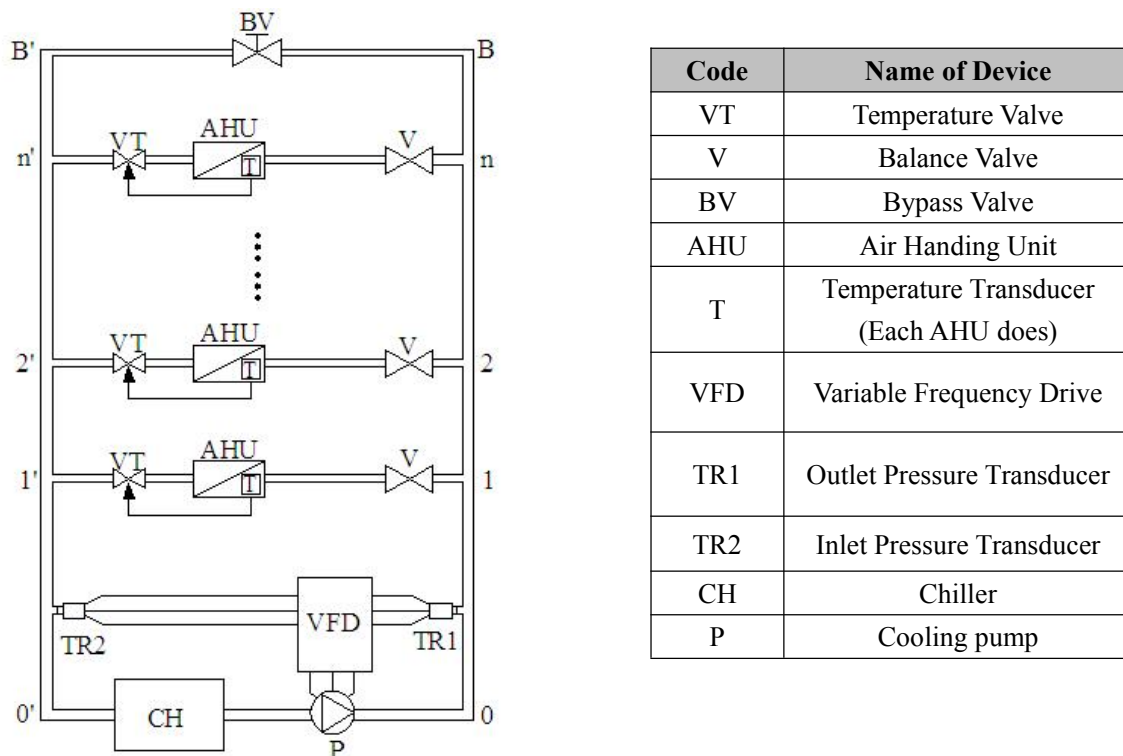

Figure8.2.1 Constant differential pressure control system

Control principle:

- When One of 1~n branches needs lower temperature and adjust AHU to turn up VT, Pressure Differential (TR1-TR2) lessens and being less than the preset value of Pressure Differential, the controller shall accelerate and make Pressure Differential return to the preset value.
- When One of 1~n branches needs higher temperature and adjust AHU to turn down VT, Pressure Differential (TR1-TR2) heightens and being higher than the preset value of Pressure Differential, the controller shall decelerate and make Pressure Differential return the preset value.
- When all branches close and still some water return Inlet of Pump to form closed water cycle, the controller is running at a low frequency at this time even be the lowest limit frequency to maintain the preset pressure differential running.

8.2.2 Typical System Wiring

Refer to Figure8.2.1, the power input and output of the central air conditioning water circulation system are connected to the corresponding models respectively. Then the outlet water pressure transducer is connected to +24V, AI1 and GND, and the backwater pressure transducer is connected to +24V, AI2 and GND. For multi-pump linkage work, use twittered-pair cable correspondingly connect to inverter's 485A port. In Figure8.2.2: QA—Automatic air switch; QF—Break; FUSE—Fuse; HB—Power light; HC—Fault light; MP—Motor and pump; BQ—Water level switch; TR1, TR3—Outlet presure transducer; TR2, TR4—Backup presure transducer; TPE—Terminal equipment. Only wants the faults and running indication will requires the HB, HC, FUSE.

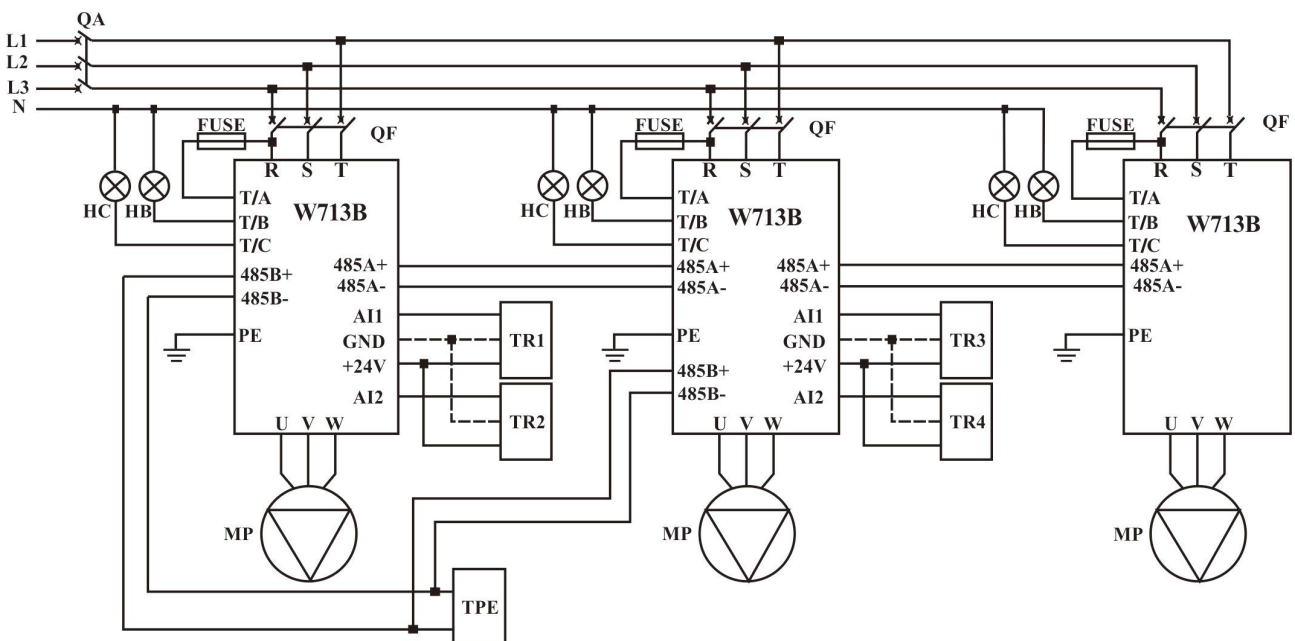

Figure8.2.2 Constant differential pressure control system wiring



Code	Factory Setting	Recommend	Description
			control , simply set the master. Terminal Start and Stop Control 
b05.10	8.00	xx.x	Alternating time, balance the service time of all pumps.
b00.03	0	1	* Anti-freezing function, valid it when the pump work under a freezing temperature.
b01.03	5.00	xx.xx	Be valid when b00.03 was set to 1, when sleep, running with the setting frequency in case of freezing. This value should be lower than the lower limited frequency (b05.07).
b02.03	50.0	xxx.x	PID parameter debugging. Increase voltage stabilization accuracy or proper regulation when Bias oversize and overwhelmed.
b02.04	2.00	x.xx	

Table 8.2.2 Multi-pump linkage constant differential pressure NO.1 slaves' setting

Code	Factory Setting	Recommend	Description
b00.00	65535	65535	Password of entering parameter groups. Factory set is 65535, it can be modified by b06.09.
b02.08	1.0	0.0	Auxiliary is need not to connect a transducer, this parameter should be set as 0. If you use the Fault Shift, this parameter of the backup master no need to modify.
b02.09	1.0	0.0	Auxiliary is need not to connect a transducer, this parameter should be set as 0. If you use the Fault Shift, this parameter of the backup master no need to modify.
b08.00~ b08.04	---	---	Ensure normal operation, must input parameter according to nameplate of motor.
b00.02	0	x	Motor rotating direction, set according to the actual motor wiring of spot. Make sure the motor is running in forward direction.
b00.07	100	x1x	 <p>Fault shift, 0: forbidden; 1: on Master and Auxiliary IP, 0: Master; 1~5: Auxiliary Numbers of pump, 1~6</p>
Below need to set based on working conditioning and user's requirement.			
b01.00	8.0	xx.x	High Water Pressure Alarm Value, prevent system from damage caused by high water pressure.
b01.01	0.5	x.x	Low Water Pressure Alarm Value, prevent pump from damage caused by anhydrous idling.
b01.05	10.0	xx.x	Transducer range, input the max. range of connected transducer
b01.16	0	x	Restart after power-on, considering unattended management, set

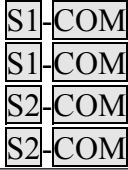

Code	Factory Setting	Recommend	Description
			parameter to 1.
b05.00	0	x	Water Level Switch type, according to the using switch type 1: NC valid; 2: NO valid
b05.02	2	3	*Notice: Only set this parameter on apply the terminal control , simply set the master. Terminal Start and Stop Control 
b05.10	8.00	xx.x	Alternating time, balance the service time of all pumps.
b00.03	0	1	* Anti-freezing function, valid it when the pump work under a freezing temperature.
b01.03	5.00	xx.xx	Be valid when b00.03 was set to 1, when sleep, running with the setting frequency in case of freezing. This value should be lower than the lower limited frequency (b05.07).
b02.03	50.0	xxx.x	PID parameter debugging. Increase voltage stabilization accuracy or proper regulation when Bias oversize and overwhelmed.
b02.04	2.00	x.xx	

Table 8.2.3 Multi-pump linkage constant differential pressure other slaves' setting

Code	Factory Setting	Recommend	Description
b00.00	65535	65535	Password of entering parameter groups. Factory set is 65535, it can be modified by b06.09.
b08.00~ b08.04			Ensure normal operation, must input parameter according to nameplate of motor.
b00.02	0	x	Motor rotating direction, set according to the actual motor wiring of spot. Make sure the motor is running in forward direction.
b00.07	100	xx0	
Below need to set based on working conditioning and user's requirement.			
b01.16	0	x	Restart after Power-on, Considering unattended management, set parameter to 1.
b05.02	2	3	*Notice: Only set this parameter on apply the terminal control , simply set the master

***Tip: After setting parameters, should press  key to make the Slave**

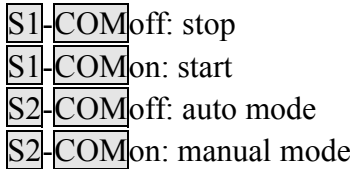
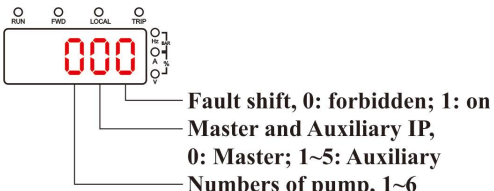
enter into remote standby status (Slave indicator power-on), then control the system start and stop via  key of the Master.

8.3 Application of Constant Temperature Water Supply

W713B product has various function, the following introduce some typical application cases of W713B constant temperature water supply and relevant parameter setting methods. In practical applications, you can reference to set.

8.3.1 Single Pump Water Supply and Parameter Setting

8.3.1.1 System Wiring

In diagram: ①W713B intelligent controller; ②Pumps group; ③Pressure tank; ④None-return valve; ⑤Temperature transducer; ⑥Water level switch (to pool); ⑦Fault indicator; ⑧Power supply indicator; ⑨Fuse; ⑩Breaker ⑪ Terminal equipment. Only wants the faults and running indication will requires ⑦⑧⑨.

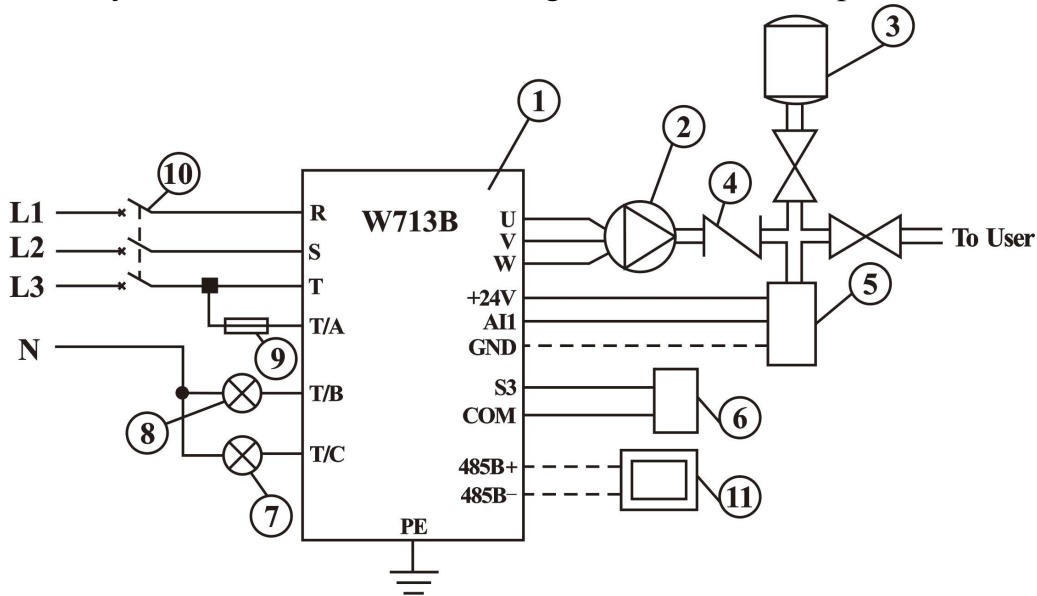

Figure8.3.1 Single pump wiring addition failure indication

1) In the figure, we adopted the transducer is two line current type transducer of the company. Others connect refers to Figure4.3.1;

2) The pool water should be used water level control switch. If the water pump is the pipeline booster pressure pump, it does not need the water level control switch.

8.3.1.2 System Debugging Procedure

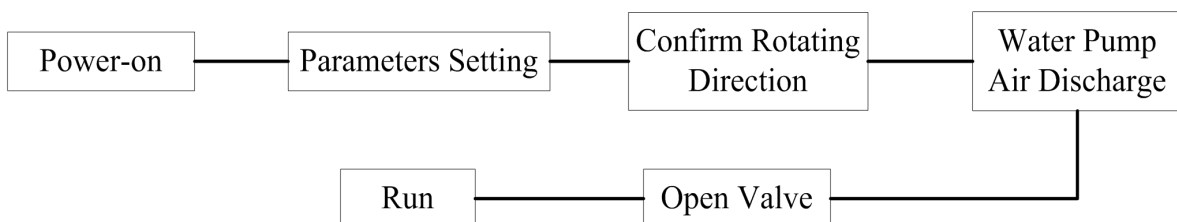

Figure8.3.2 Debugging flow diagram

8.3.1.3 Relevant Parameter Setting

Table 8.3.1 Parameter setting of single pump constant temperature control water supply

Code	Factory Setting	Recommend	Description
b00.00	65535	65535	Password of entering parameter groups. Factory set is 65535, it can be modified by b06.09.
b08.00~ b08.04			Ensure normal operation, must input parameter according to nameplate of motor.
b00.02	0	x	Motor rotating direction, set according to the actual motor wiring of spot. Make sure the motor is running in forward direction.
b01.18	0	2	Constant temperature
Below need to set based on working conditioning and user's requirement.			
b00.01	30.0	x.x	The temperature of water supply
b01.28	90.0	xx.x	High Temperature Alarm Value, prevent system from damage caused by high temperature.
b01.29	-15.0	xxx.x	Low Temperature Alarm Value, prevent pump from damage caused by low temperature
b01.07	0.0	xxx.x	All Lower limit of temperature, set the minimum value of transducer range
b01.09	100.0	xxx.x	All Upper limit of temperature, set the maximum value of transducer range
b01.06	1.00	x.xx	Use to transducer zero setting
b01.08	5.00	x.xx	When display smaller than gauge, decrease b01.08; When display greater than gauge, increase b01.08.
b01.16	1	x	Restart after Power-on, considering unattended management, set parameter to 1.
b05.00	0	x	Water Level Switch type, according to the using switch type 1: NC valid 2: NO valid
b05.02	2	3	<p>*Notice: Only set this parameter on apply the terminal control, simply set the master.</p> <p> <input type="checkbox"/> S1-COM off: stop <input type="checkbox"/> S1-COM on: start <input type="checkbox"/> S2-COM off: auto mode <input type="checkbox"/> S2-COM on: manual mode </p>
b00.03	0	1	* Anti-freezing function, valid it when the pump work under a freezing temperature.
b01.03	5.00	xx.xx	Be valid when b00.03 was set to 1, when sleep, running with the setting frequency in case of freezing. This value should be lower than the lower limited frequency (b05.07).
b02.03	50.0	xxx.x	PID parameter debugging. Increase voltage stabilization accuracy or proper regulation when Bias oversize and overwhelmed.
b02.04	2.00	x.xx	

8.3.2 Multi-pump Control

8.3.2.1 Typical System Wiring

In diagram: QA—Automatic air switch; QF—Break; FUSE—Fuse; HB—Power light; HC—Fault light; MP—Motor and pump; BQ—Water level switch; BP1—Outlet temperature transducer; BP2—Backup temperature transducer; TPE—Terminal equipment. Only wants the faults and running indication will requires the FUSE, HB, HC.

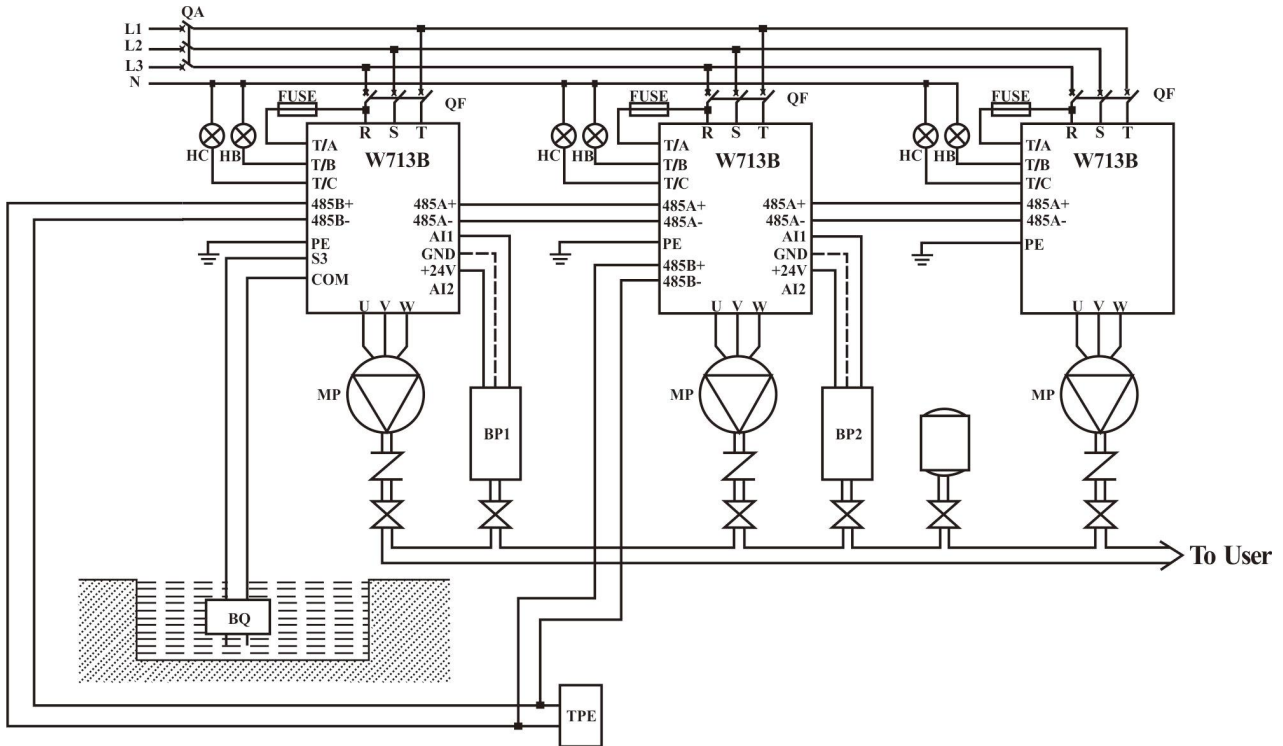
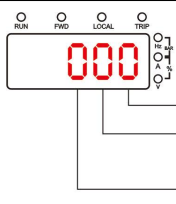

Figure8.3.3 Multi-pump linkage constant temperature water supply wiring

8.3.2.2 Relevant Parameter Setting

Table 8.3.2 Multi-pump linkage constant temperature master setting

Code	Factory Setting	Recommend	Description
b00.00	65535	65535	Password of entering parameter groups. Factory set is 65535, it can be modified by b06.09.
b08.00~b08.04			Ensure normal operation, must input parameter according to nameplate of motor.
b00.02	0	x	Motor rotating direction, set according to the actual motor wiring of spot. Make sure the motor is running in forward direction.
b00.07	100	x0x	 <p>Fault shift, 0: forbidden; 1: on Master and Auxiliary IP, 0: Master; 1~5: Auxiliary Numbers of pump, 1~6</p>
b01.18	0	2	Constant temperature
Below need to set based on working conditioning and user's requirement.			
b00.01	30.0	x.x	The temperature of water supply
b01.28	90.0	xx.x	High Temperature Alarm Value, prevent system from damage



Code	Factory Setting	Recommend	Description												
b00.02	0	x	Motor rotating direction, set according to the actual motor wiring of spot. Make sure the motor is running in forward direction.												
b00.07	100	x1x	 <p>Fault shift, 0: forbidden; 1: on Master and Auxiliary IP, 0: Master; 1~5: Auxiliary Numbers of pump, 1~6</p>												
Below need to set based on working conditioning and user's requirement.															
b01.28	90.0	xx.x	High Temperature Alarm Value, prevent system from damage caused by high temperature.												
b01.29	-15.0	xxx.x	Low Temperature Alarm Value, prevent pump from damage caused by low temperature												
b01.07	0.0	xxx.x	All Lower limit of temperature, set the minimum value of transducer range												
b01.09	100.0	xxx.x	All Upper limit of temperature, set the maximum value of transducer range												
b01.16	1	x	Restart after Power-on, considering unattended management, set parameter to 1.												
b05.00	0	x	Water Level Switch type, according to the using switch type 1: NC valid; 2: NO valid												
b05.02	2	3	<p>*Notice: Only set this parameter on apply the terminal control , simply set the master.</p> <p>Terminal Start and Stop Control</p> <table border="1" data-bbox="635 1220 762 1384"> <tr> <td>S1</td> <td>COM</td> <td>off: stop</td> </tr> <tr> <td>S1</td> <td>COM</td> <td>on: start</td> </tr> <tr> <td>S2</td> <td>COM</td> <td>off: auto mode</td> </tr> <tr> <td>S2</td> <td>COM</td> <td>on: manual mode</td> </tr> </table>	S1	COM	off: stop	S1	COM	on: start	S2	COM	off: auto mode	S2	COM	on: manual mode
S1	COM	off: stop													
S1	COM	on: start													
S2	COM	off: auto mode													
S2	COM	on: manual mode													
b05.10	8.00	xx.x	Alternating time, balance the service time of all pumps.												
b00.03	0	1	* Anti-freezing function, valid it when the pump work under a freezing temperature.												
b01.03	5.00	xx.xx	Be valid when b00.03 was set to 1, when sleep, running with the setting frequency in case of freezing. This value should be lower than the lower limited frequency (b05.07).												
b02.03	50.0	xxx.x	PID parameter debugging. Increase voltage stabilization accuracy or proper regulation when Bias oversize and overwhelmed.												
b02.04	2.00	x.xx													

Table 8.3.4 Multi-pump linkage constant temperature other slaves' setting

Code	Factory Setting	Recommend	Description
b00.00	65535	65535	Password of entering parameter groups. Factory set is 65535, it can be modified by b06.09.
b08.00~ b08.04			Ensure normal operation, must input parameter according to nameplate of motor.

Code	Factory Setting	Recommend	Description												
b00.02	0	x	Motor rotating direction, set according to the actual motor wiring of spot. Make sure the motor is running in forward direction.												
b00.07	100	xx0	 <p>Fault shift, 0: forbidden; 1: on Master and Auxiliary IP, 0: Master; 1~5: Auxiliary Numbers of pump, 1~6</p>												
Below need to set based on working conditioning and user's requirement.															
b01.16	1	x	Restart after Power-on, considering unattended management, set parameter to 1.												
b05.02	2	3	<p>*Notice: Only set this parameter on apply the terminal control , simply set the master.</p> <p>Terminal Start and Stop Control</p> <table border="1" style="margin-left: 20px;"> <tr> <td>S1</td> <td>COM</td> <td>off: stop</td> </tr> <tr> <td>S1</td> <td>COM</td> <td>on: start</td> </tr> <tr> <td>S2</td> <td>COM</td> <td>off: auto mode</td> </tr> <tr> <td>S2</td> <td>COM</td> <td>on: manual mode</td> </tr> </table>	S1	COM	off: stop	S1	COM	on: start	S2	COM	off: auto mode	S2	COM	on: manual mode
S1	COM	off: stop													
S1	COM	on: start													
S2	COM	off: auto mode													
S2	COM	on: manual mode													

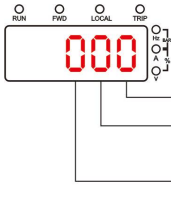
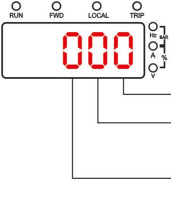
***Tip: After setting parameters, should press  key to make the Slave enter into remote standby status (Slave indicator power-on), then control the system start and stop via  key of the Master.**

8.4 Application of Constant Differential Temperature Water Supply

W713B series product have rich functions, the typical application modes and related parameter setting methods of intelligent constant temperature differential water supply for W713B series pump are introduced below, which can be set for your reference in actual application.

8.4.1 Differential Temperature Control System Introduction.

Figure8.4.1 is the schematic diagram of the central air-conditioning water circulation system. The VFD in the figure is the W713B Controller. In the application, adopt Dual-Transducers mode to get the feedbacks from inlet and outlet temperature value separately to controller's receiving port to realize constant temperature linkage differential control.

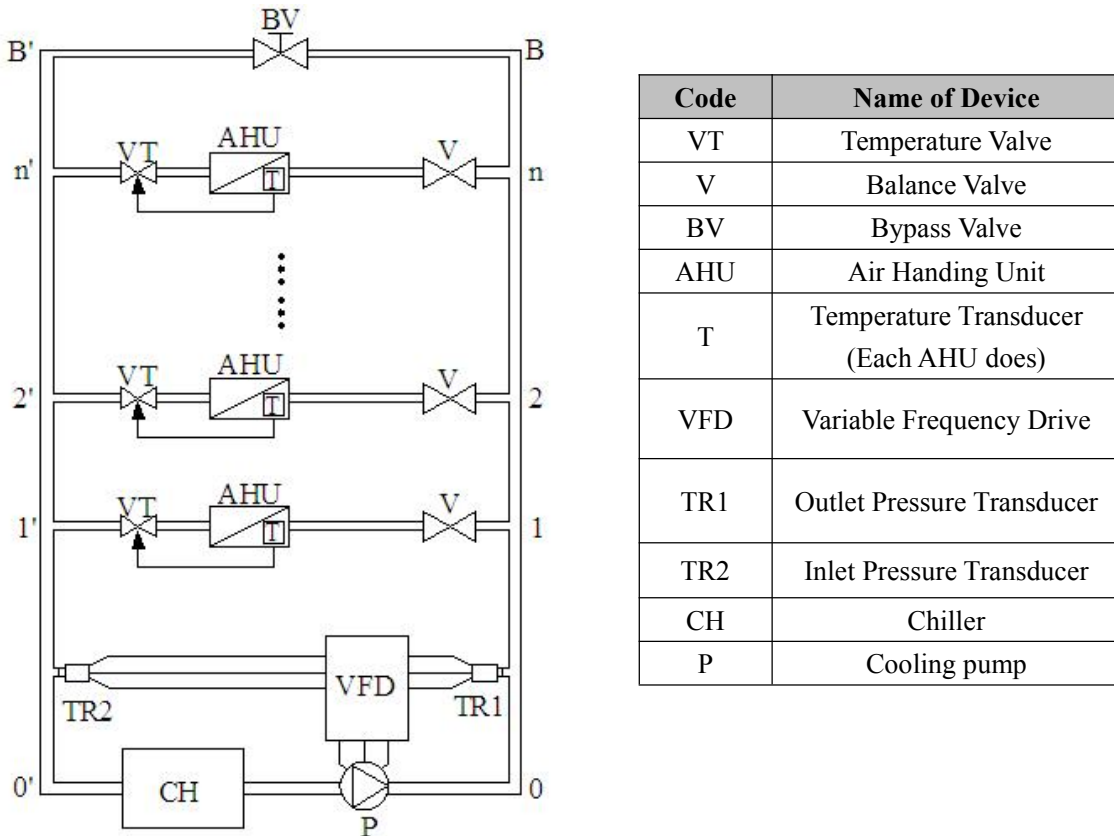

Figure8.4.1 Constant differential temperature control system

Control principle:

- When One of 1~n branches needs lower temperature and adjust AHU to turn up VT, Temperature Differential (TR1-TR2) heightens and being higher than the preset value of Temperature Differential, the controller shall accelerate and make Temperature Differential return to the preset value.
- When One of 1~n branches needs higher temperature and adjust AHU to turn down VT, Temperature Differential (TR1-TR2) lessens and being less than the preset value of Temperature Differential, the controller shall decelerate and make Temperature Differential return the preset value.
- When all branches close and still some water return Inlet of Pump to form closed water cycle, the controller is running at a low frequency at this time even be the lowest limit frequency to maintain the preset temperature differential running.

8.4.2 Typical System Wiring

Refer to Figure8.4.1, the power input and output of the central air conditioning water circulation system are connected to the corresponding models respectively. Then the outlet water temperature transducer is connected to +24V, AI1 and GND, and the backwater temperature transducer is connected to +24V, AI2 and GND. For multi-pump linkage work, use twittered-pair cable correspondingly connect to inverter's 485A port. In Figure8.2.2: QA—Automatic air switch; QF—Break; FUSE

—Fuse; HB—Power light; HC—Fault light; MP—Motor and pump; BQ—Water level switch; TR1, TR3—Outlet temperature transducer; TR2, TR4—Backup temperature transducer; TPE—Terminal equipment. Only wants the faults and running indication will requires the HB, HC, FU.

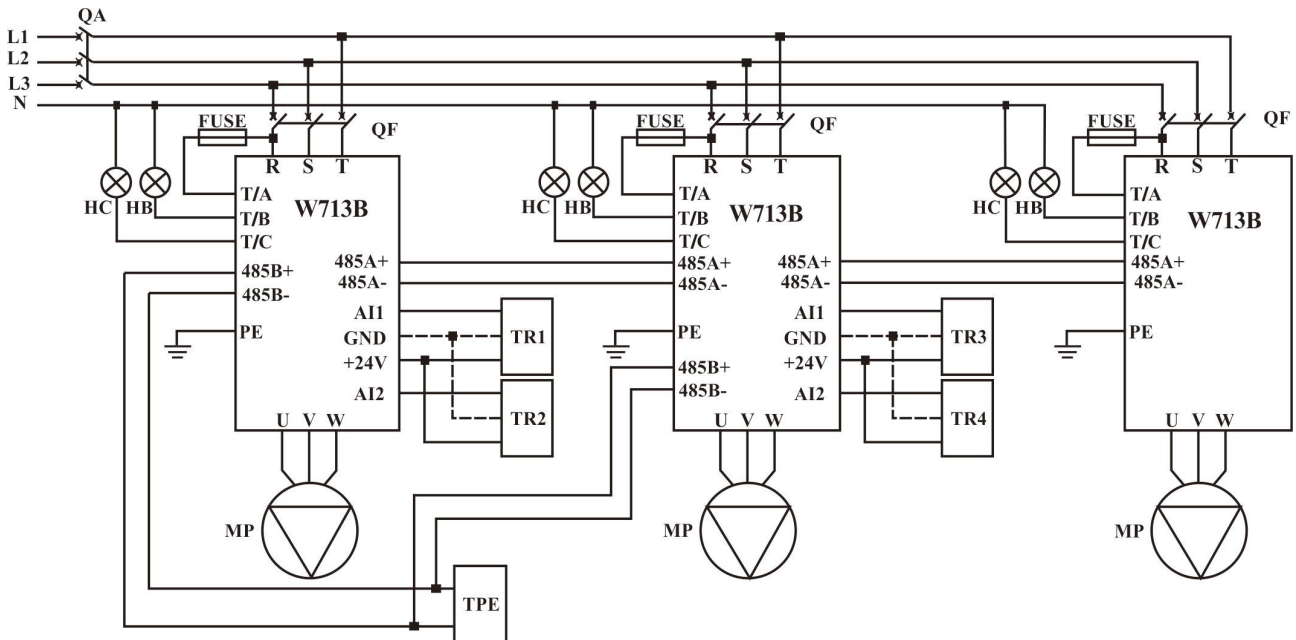

Figure 8.4.2 Constant differential temperature control system wiring

8.4.3 System Debugging Procedure

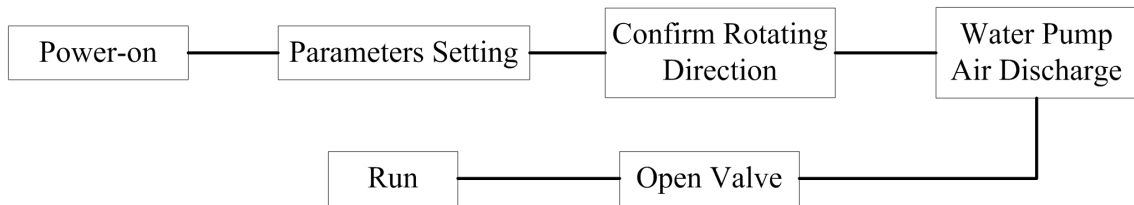



Figure 8.4.3 Debugging flow diagram

8.4.4 Relevant Parameter Setting

Table 8.4.1 Multi-pump linkage constant differential temperature master setting

Code	Factory Setting	Recommend	Description
b00.00	65535	65535	Password of entering parameter groups. Factory set is 65535, it can be modified by b06.09.
b08.00~b08.04			Ensure normal operation, must input parameter according to nameplate of motor.
b00.02	0	x	Motor rotating direction, set according to the actual motor wiring of spot. Make sure the motor is running in forward direction.
b00.07	100	x0x	 <p>Fault shift, 0: forbidden; 1: on Master and Auxiliary IP, 0: Master; 1-5: Auxiliary Numbers of pump, 1-6</p>

Code	Factory Setting	Recommend	Description												
b01.18	0	3	Constant Differential Temperature												
b02.02	1	1	PID takes reaction.												
Below need to set based on working conditioning and user's requirement.															
b00.01	5.0	x.x	The differential temperature of water supply												
b01.28	90.0	xxx.x	High Temperature Alarm Value, prevent system from damage caused by high temperature.												
b01.29	-15.0	xxx.x	Low Temperature Alarm Value, prevent pump from damage caused by low temperature												
b01.07	0.0	xxx.x	AI1 Lower limit of temperature, set the minimum value of transducer range												
b01.09	100.0	xxx.x	AI1 Upper limit of temperature, set the maximum value of transducer range												
b01.12	0.0	xxx.x	AI2 Lower limit of temperature, set the minimum value of transducer range												
b01.14	100.0	xxx.x	AI2 Upper limit of temperature, set the maximum value of transducer range												
b01.11	1.00	x.xx	Use to AI2 transducer zero setting (Inlet side temperature)												
b01.06	1.00	x.xx	Use to AI1 transducer zero setting (outlet side temperature)												
b01.13	5.00	x.xx	When display inlet side temperature smaller than gauge, decrease b01.13; When display inlet side temperature greater than gauge, increase b01.13.												
b01.08	5.00	x.xx	When display temperature differential smaller than gauge, decrease b01.08; When display temperature differential greater than gauge, increase b01.08.												
b01.16	0	x	Restart after power-on, considering unattended management, set parameter to 1.												
b01.17	1	x	Linkage Mode 0: Synchronous; 1: Master-slave; 2: Big-small pump combination; 3: One duty one standby												
b05.00	0	x	Water Level Switch type, according to the using switch type 1: NC valid; 2: NO valid												
b05.02	2	3	*Notice: Only set this parameter on apply the terminal control , simply set the master. Terminal Start and Stop Control <table border="1" style="margin-left: 20px;"> <tr> <td>S1</td> <td>-COM</td> <td>off: stop</td> </tr> <tr> <td>S1</td> <td>-COM</td> <td>on: start</td> </tr> <tr> <td>S2</td> <td>-COM</td> <td>off: auto mode</td> </tr> <tr> <td>S2</td> <td>-COM</td> <td>on: manual mode</td> </tr> </table>	S1	-COM	off: stop	S1	-COM	on: start	S2	-COM	off: auto mode	S2	-COM	on: manual mode
S1	-COM	off: stop													
S1	-COM	on: start													
S2	-COM	off: auto mode													
S2	-COM	on: manual mode													
b05.10	8.00	xx.x	Alternating time, balance the service time of all pumps.												
b00.03	0	1	* Anti-freezing function, valid it when the pump work under a freezing temperature.												
b01.03	5.00	xx.xx	Be valid when b00.03 was set to 1, when sleep, running with the setting frequency in case of freezing. This value should be lower												

Code	Factory Setting	Recommend	Description
			than the lower limited frequency (b05.07).
b02.03	50.0	xxx.x	PID parameter debugging. Increase voltage stabilization accuracy or proper regulation when Bias oversize and overwhelmed.
b02.04	2.00	x.xx	

Table 8.4.2 Multi-pump linkage constant temperature differential NO.1 slaves' setting

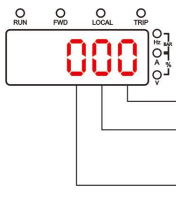
Code	Factory Setting	Recommend	Description
b00.00	65535	65535	Password of entering parameter groups. Factory set is 65535, it can be modified by b06.09.
b02.08	1.0	x.x	Auxiliary is need not to connect AI1 transducer, this parameter should be set as 0. If you use the Fault Shift, this parameter of the backup master no need to modify.
b02.09	1.0	x.x	Auxiliary is need not to connect AI2 transducer, this parameter should be set as 0. If you use the Fault Shift, this parameter of the backup master no need to modify.
b08.00~ b08.04	----	----	Ensure normal operation, must input parameter according to nameplate of motor.
b00.02	0	x	Motor rotating direction, set according to the actual motor wiring of spot. Make sure the motor is running in forward direction.
b00.07	100	x1x	 <p>Fault shift, 0: forbidden; 1: on Master and Auxiliary IP, 0: Master; 1-5: Auxiliary Numbers of pump, 1-6</p>

Below need to set based on working conditioning and user's requirement.

b00.01	5.0	x.x	The differential temperature of water supply
b01.28	90.0	xxx.x	High Temperature Alarm Value, prevent system from damage caused by high temperature.
b01.29	-15.0	xxx.x	Low Temperature Alarm Value, prevent pump from damage caused by low temperature
b01.07	0.0	xxx.x	AI1 Lower limit of temperature, set the minimum value of transducer range
b01.09	100.0	xxx.x	AI1 Upper limit of temperature, set the maximum value of transducer range
b01.12	0.0	xxx.x	AI2 Lower limit of temperature, set the minimum value of transducer range
b01.14	100.0	xxx.x	AI2 Upper limit of temperature, set the maximum value of transducer range
b01.16	0	x	Restart after power-on, considering unattended management, set parameter to 1.
b05.00	0	x	Water Level Switch type, according to the using switch type 1: NC valid; 2: NO valid
b05.02	2	3	*Notice: Only set this parameter on apply the terminal control , simply set the master.



Code	Factory Setting	Recommend	Description
			Terminal Start and Stop Control 
b05.10	8.00	xx.x	Alternating time, balance the service time of all pumps.
b00.03	0	1	* Anti-freezing function, valid it when the pump work under a freezing temperature.
b01.03	5.00	xx.xx	Be valid when b00.03 was set to 1, when sleep, running with the setting frequency in case of freezing. This value should be lower than the lower limited frequency (b05.07).
b02.03	50.0	xxx.x	PID parameter debugging. Increase voltage stabilization accuracy or proper regulation when Bias oversize and overwhelmed.
b02.04	2.00	x.xx	

Table 8.4.3 Multi-pump linkage constant temperature differential other slaves' setting

Code	Factory Setting	Recommend	Description
b00.00	65535	65535	Password of entering parameter groups. Factory set is 65535, it can be modified by b06.09.
b08.00~ b08.04			Ensure normal operation, must input parameter according to nameplate of motor.
b00.02	0	x	Motor rotating direction, set according to the actual motor wiring of spot. Make sure the motor is running in forward direction.
b00.07	100	xx0	 <p>Fault shift, 0: forbidden; 1: on Master and Auxiliary IP, 0: Master; 1~5: Auxiliary Numbers of pump, 1~6</p>
Below need to set based on working conditioning and user's requirement.			
b01.16	0	x	Restart after Power-on, Considering unattended management, set parameter to 1.
b05.02	2	3	*Notice: Only set this parameter on apply the terminal control , simply set the master

***Tip:** After setting parameters, should press  key to make the Slave enter into remote standby status (Slave indicator power-on), then control the system start and stop via  key of the Master.

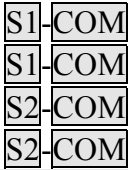
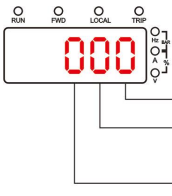
8.5 Manual/Auto Control Wiring and Setting



8.5.1 System Wiring

Base on above applications, connect a switch to **S2-COM**. Normally apply this function on slaves.

8.5.2 Operation

Widely use in building site manual control water supply, new pipe system quick fill etc. needs full-frequency running place.

Terminal switching control: Switch on **S2-COM**, switch to the constant speed mode (manual mode). The inverter will immediately operate according to the set value of constant speed operating frequency. Switch off **S2-COM**, switch to the constant pressure /constant differential pressure /constant temperature /constant differential temperature mode (automatic mode), the start-stop control is controlled by the panel keys.

Panel Keypad switching control: In the stop state, press the  and  key at the same time in the primary display interface to realize the manual/automatic switchover. The start-stop control is controlled by the panel keys.

8.5.3 Relevant Parameter Setting

According to all the previous application to set parameters at first, and then set b05.02=2 of slaves with Switch on **S2-COM**.

8.6 Electric Contact Gauge Water Supply

8.6.1 System Wiring

In diagram: ①W713B intelligent controller; ②Pumps; ③Check valve; ④Butterfly valve; ⑤ Pressure switch; ⑥Water level switch; ⑦Terminal equipment

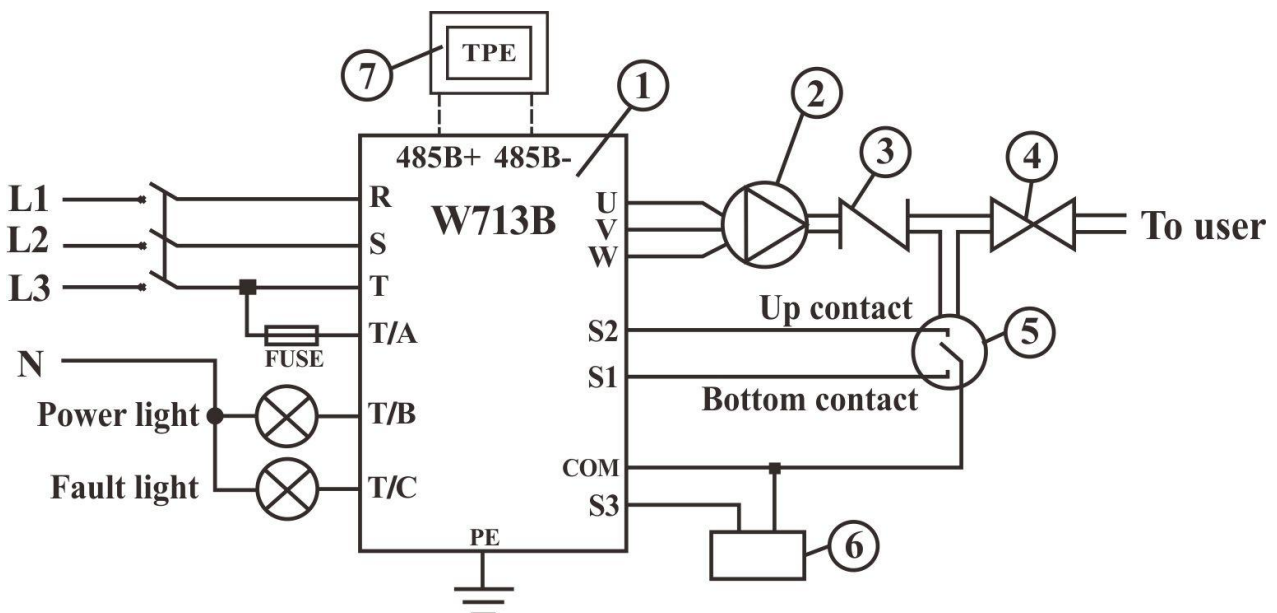

Figure8.6.1 Electric contact pressure gauge control wiring diagram

8.6.2 Relevant Parameter Setting

This example use the electric contact pressure gauge instead of the transducer, adjust the gauge's up electric contact and bottom electric contact to the range of need is should be done before running. For example, want a 0.3MPa water supply, then up contact adjust above scale 0.3MPa (such as at 0.32MPa), bottom electric contact below 0.3MPa (such as at 0.28MPa).

8.6.3 Relevant Parameter Setting

Table 8.6.1 Electric contact pressure gauge control setting

Code	Factory Setting	Recommend	Description
b00.00	65535	65535	Password of entering parameter groups. Factory set is 65535, it can be modified by b06.09.
b08.00 ~b08.04			Ensure normal operation, must input parameter according to nameplate of Motor.
b00.02	0	x	Motor rotating direction, set according to the actual motor wiring of spot. Make sure the motor is running in forward direction.
b02.08	1.0%	0.0%	AI1 feedback lost detecting value, this application need not pressure detect, set the parameter 0.
b05.02	2	1	Terminal S1, S2 control, set as electric contact pressure gauge control.
Below need to set based on working conditioning and user's requirement.			
b01.16	1	x	Restart after power-on, considering unattended management, set parameter to 1.
b05.00	2	x	Water level (terminal S3) switch type, according to the using switch type 1: NC valid; 2: NO valid
b05.03			Acc. and Dec. time. It is recommended to set equal or above 20s, a short acc./dec. time lead to a fluctuate control.
b05.04			

8.7 Application of One VFD Drive Two Pump

W713B series product have rich functions, the typical application modes and related parameter setting methods of one VFD drive two pump water supply for W713B series pump are introduced below, which can be set for your reference in actual application.

8.7.1 Relevant Parameter Setting

Refer to Figure8.7.1 and Figure8.7.2 in diagram: QF1, QF2, QF3 — Breaker; 1KM, 2KM, 3KM, 4KM, 5KM, 6KM, 7KM, 8KM — Contactor; 1FR, 2FR — Thermorelay; 1KA, 2KA — Middle relay coil; M — Pump; SB1, SB3 — Mmanual start switch; SB2, SB4 — Manual stop switch.

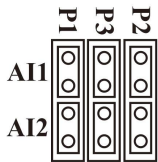
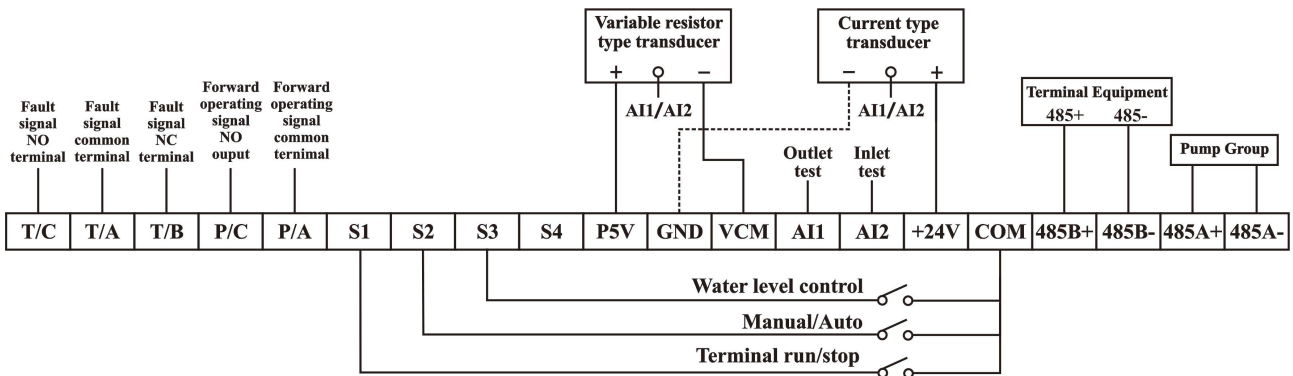

P1: Transducer selection switch, plug in the short circuit cap as current signal, otherwise voltage signal.
P2: 485A communication terminal resistance selection, plug in the short circuit cap to connect terminal resistor and otherwise. Note that plug the short-circuit caps on the first and tail two when multiple pumps are online. that for multi-pump, only open toggle switch of the first pump and last pump.
P3: 485B communication terminal resistance selection, plug in the short circuit cap to connect terminal resistor and otherwise. Note that plug the short-circuit caps on the first and tail two when multiple pumps are online. that for multi-pump, only open toggle switch of the first pump and last pump.

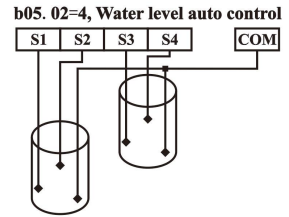

Figure 8.7.1 Single pump water supply system wiring

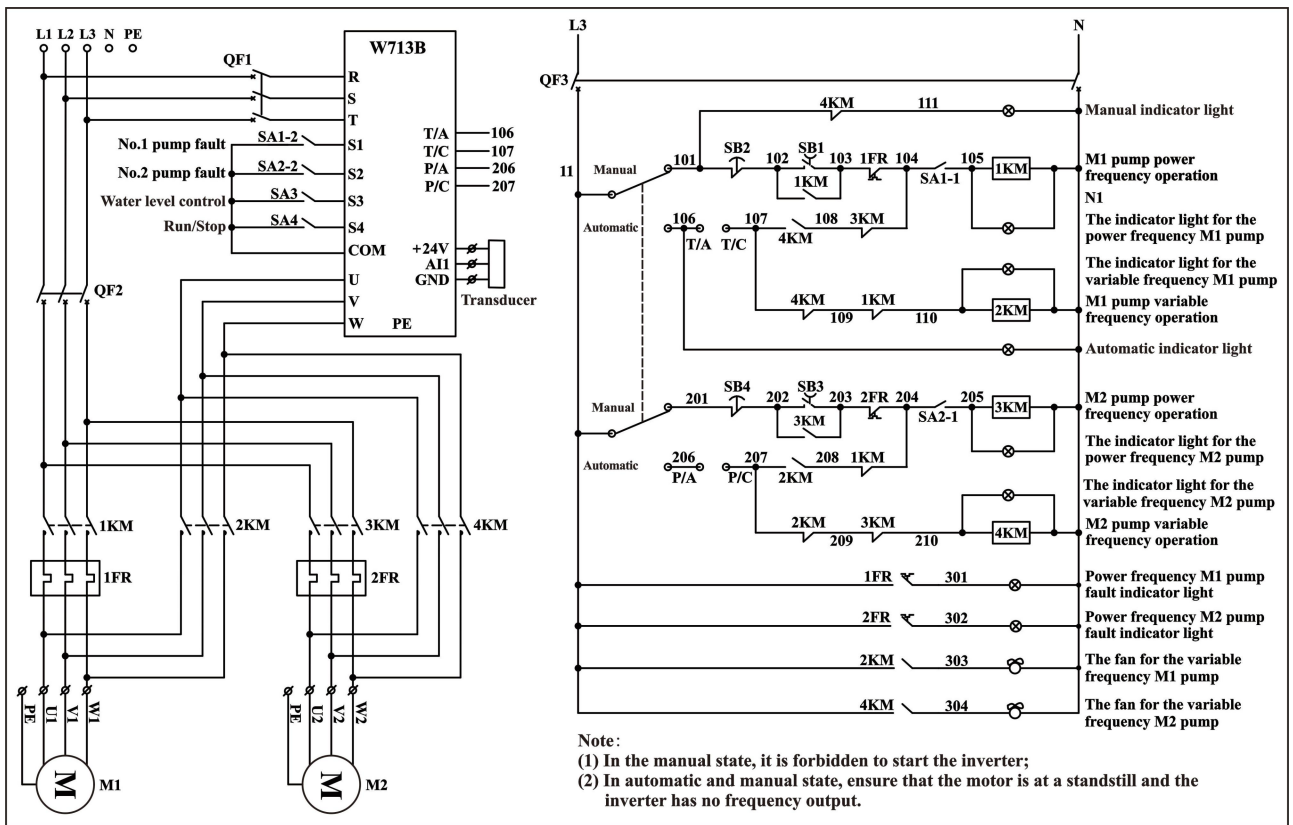

Figure 8.7.2 0.75kW~7.5kW One VFD drive two pumps wiring

Control principle:

- (1) Switch on QF1, QF2, QF3 set inverter parameters according to Table 8.7.1.
- (2) Manual Control: Close manual control, press button SB1, pump M1 runs at power frequency; press button SB3, pump M2 runs at power frequency; press button SB2, pump M1 stop; press button SB4, pump M2 stop.

(3) Auto Control: Close auto control, pump M1 become variable frequency pump, close inverter start switch, inverter start working. When the pressure is insufficient, variable frequency pump accelerate to the upper limit frequency, the feedback pressure is lower than the adding pump pressure (b00.01-b01.21), after the delay time b01.22, variable frequency pump freely stop and meanwhile pump M2 runs at power frequency, after the delay time b01.27, pump M1 runs at variable frequency.

After sleep, pump M2 switches to variable frequency pump. when the pressure is insufficient, variable frequency pump accelerate to the upper limit frequency, the feedback pressure is lower than the adding pump pressure (b00.01-b01.21), after the delay time b01.22, variable frequency pump freely stop and meanwhile pump M1 runs at power frequency, after the delay time b01.27, pump M2 runs at variable frequency.

When the two pump are running at the same time, if the pressure is too high, inverter will decelerate to the lower limit frequency b05.07 and keep running for the time b01.26 and subtract the power frequency pump. if feedback pressure is higher than ultimate pressure (b00.01+b01.25), after 3 secs will subtract power frequency pump immediately.

8.7.2 System Debugging Procedure

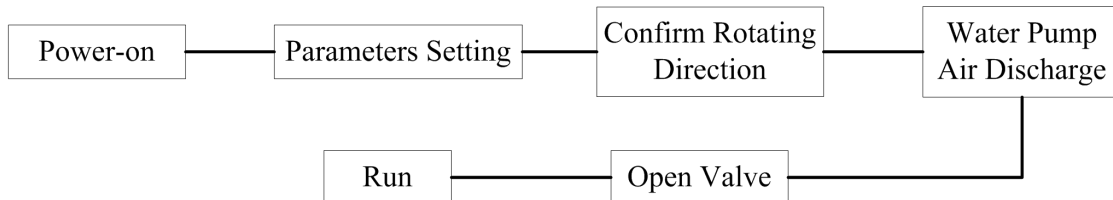



Figure 8.7.3 Debugging flow diagram

8.7.3 Relevant Parameter Setting

Table 8.7.1 One VFD drive two pump parameter setting

Code	Factory Setting	Recommend	Description
b00.00	65535	65535	Password of entering parameter groups. Factory set is 65535, it can be modified by b06.09.
b08.00 ~b08.04			Ensure normal operation, must input parameter according to nameplate of motor.
b00.02	0	x	Motor rotating direction, set according to the actual motor wiring of spot. Make sure the motor is running in forward direction.
b00.07	100	x00	 <p>Fault shift, 0: forbidden; 1: on Master and Auxiliary IP, 0: Master; 1~5: Auxiliary Numbers of pump, 1~6</p>

Code	Factory Setting	Recommend	Description
			When connected to touch screen, the setting is 200/300/400/500/600
b01.18	0	0	Constant pressure
b01.17	1	4	One VFD drive two pumps (It needs to be used with One VFD drive two pumps boxes) Note: when b01.17 was set to 4, the following parameters will be set automatically. b01.09 is 0 (Independent Start and Stop Forbidden), b05.02 is 5 (One VFD drives two pump fault input), b05.12 is 1 (S4 terminal control), b06.03 is 10 (Relay 1 used for variable frequency pump control), b06.10 is 11(Relay 2 used for power frequency pump control).
Below need to set based on working conditioning and user's requirement.			
b00.01	3.0	x.x	The pressure of water supply
b01.00	8.0	xx.x	High Water Pressure Alarm Value, prevent system from damage caused by high water pressure.
b01.01	0.5	x.x	Low Water Pressure Alarm Value, prevent pump from damage caused by anhydrous idling.
b01.05	10.0	xx.x	Transducer range, input the max. range of connected transducer
b01.06	1.00	x.xx	Use to transducer zero setting
b01.08	5.00	x.xx	When display smaller than gauge, decrease b01.08; When display greater than gauge, increase b01.08.
b01.16	1	x	Restart after Power-on, considering unattended management, set parameter to 1.
b01.20	1	x	When enabled, the alternate mode is determined by b05.11, and the alternate time is set by b05.10. Note: After the alternate time reaches, when the sleep function is enabled, the system will automatically complete the alternate while sleeping. When the sleep function is not enabled, the system will complete the alternating at the lower limit of output frequency.
b01.21	0.5	x.x	Add Power Frequency Pump Pressure Bias
b01.22	10.0	xx.x	Add Power Frequency Pump Delay Time
b01.23	0.5	x.x	Subtract Power Frequency Pump Pressure Bias
b01.24	10.0	xx.x	Subtract Power Frequency Pump Delay Time
b01.25	1.0	x.x	Subtract Power Frequency Pump Ultimate Pressure Bias
b01.26	10.0	xx.x	Subtract Power Frequency Lower Limit Frequency Retention Time
b01.27	3.0	x.x	Add Variable Frequency Pump Delay Time
b05.00	0	x	Water Level Switch type, according to the using switch type 1: NC valid; 2: NO valid
b05.10	8.00	xx.x	Alternating time, balance the service time of all pumps.
b05.11	0	x	0: Alternate according to alternating time or sleeping wake-up

Code	Factory Setting	Recommend	Description
			1: Only alternate according to alternating time
b02.03	50.0	xxx.x	PID parameter debugging. Increase voltage stabilization accuracy or proper regulation when Bias oversize and overwhelmed.
b02.04	2.00	x.xx	

8.8 Application Summary

W713B intelligent water supply controller owns powerful function, to be intelligent water supply, beside previous typical applications, it covers most applications. Such as, air conditioning cold water pump, cooling pump constant temperature automatic control, hot water circulation system(include solar energy, heat pump water supply etc.), water treatment system, garden landscape, industry and agriculture production water supply system. User is urged according to spot condition and various functions of W713B to fulfill a good performance water supply.

W713B intelligent constant water supply controller haven't special demands to peripherals, it almost can be use the normal component. Such as water detection use transducer, transmitter (include water level transmitter, temperature transmitter, etc.) or inductive remote transmission pressure gauge, its output is 4~20mA, 0~5VDC and 0~10 VDC standard signal. For a easy control, use an electric contact pressure gauge or pressure switch can be achieved; Water level switch can use the float switch or pressure switch and so on general application device. All of this allows user according to the work condition select appropriate peripheral device.

9. FAULT AND TROUBLE SHOOTING

9.1 System Running Fault and Trouble Shooting

Abnormal Function	Reason	Solution
Can't Sleep	<ol style="list-style-type: none"> 1. Outlet pipe leakage; 2. Check valve leakage; 3. Pressure tank damage; 4. High environment EMI; 5. Wrong parameter 	<ul style="list-style-type: none"> ● Check outlet pipe, or to set b04.04; ● Inspect check valve; ● Change pressure tank; ● Transducer adopt shielded wires, shielded layer connect to PE; ● Ensure b04.00 = 1
Display Pressure Error	<ol style="list-style-type: none"> 1. Detector error; 2. Wrong parameter; 3. Transducer wires is too long 	<ul style="list-style-type: none"> ● Adopt standard detector; ● Calibration parameter b01.05, b01.06, b01.08, b01.11, b01.13; ● Avoid use too long transducer wires
Full-Frequency Running	<ol style="list-style-type: none"> 1. Lose pressure feedback; 2. Wrong parameter; 3. Pump under power 	<ul style="list-style-type: none"> ● Check transducer and wires; ● b05.02 should not be set as 1; ● S2-Com should be open;

Abnormal Function	Reason	Solution
		<ul style="list-style-type: none"> ● Set b07.01 = 1, take a factory reset
Pressure Vibration, Stabilize Slow	<ol style="list-style-type: none"> 1. PID value unmatched; 2. Acc. /Dec. time too fast; 3. Big delay on pressure feedback 	<ul style="list-style-type: none"> ● Tune PI value b02.03, b02.04; ● Tune Acc./Dec. time b05.03, b05.04; ● Avoid use too long transducer wires
Motor Noise	<ol style="list-style-type: none"> 1. Motor abnormal; 2. Motor installation is not stable; 3. Low carry-frequency 	<ul style="list-style-type: none"> ● Check motor; ● Proper turn up carrier frequency b05.08

9.2 Water Supply Running Fault and Trouble Shooting

Fault Code	Fault value	Fault Type	Reason	Solution
LP	0x1C	Low Water Pressure	<ol style="list-style-type: none"> 1. Abnormal sensor; 2. Motor rotates in the reverse direction; 3. Insufficient water inflow; 4. There is air inside the pump 	<ul style="list-style-type: none"> ● Check the installation of pressure transducer; ● Check the motor's direction of rotation is correct or not; ● Check the parameter b01.01 (setting value too big); ● Check the pump whether is vent out the air inside
LP2	0x2A	Low Water Pressure at Inlet	<ol style="list-style-type: none"> 1. Abnormal sensor; 2. Insufficient water inflow 	<ul style="list-style-type: none"> ● Check the installation of pressure transducer; ● Check the parameter b07.00 (setting value too big)
HP	0x1B	High Water Pressure	<ol style="list-style-type: none"> 1. Abnormal sensor; 2. The parameter b01.00 setting value is too small 	<ul style="list-style-type: none"> ● Check the installation of pressure transducer; ● Check the parameter b01.00 (setting value too small)
LT	0x20	Low Temperature	<ol style="list-style-type: none"> 1. Abnormal sensor; 2. The temperature is too low 	<ul style="list-style-type: none"> ● Check the installation of temperature transducer; ● Check parameter b01.29 value set whether is too large
LT2	0x2B	Low Temperature at Inlet	<ol style="list-style-type: none"> 1. Abnormal sensor; 2. The temperature at inlet is too low 	<ul style="list-style-type: none"> ● Check the installation of temperature transducer; ● Check the parameter b07.00 (setting value too big);
HT	0x1F	High Temperature	<ol style="list-style-type: none"> 1. Abnormal sensor; 2. The parameter b01.28 setting value is too small 	<ul style="list-style-type: none"> ● Check the installation of temperature transducer; ● Check the parameter b01.28 (setting value too small)
LL	0x29	Low Water Level	<ol style="list-style-type: none"> 1. Water level of pool is too low; 2. Abnormal water level switch; 3. Wrong setting of water level switch style parameter 	<ul style="list-style-type: none"> ● Check the water system ● Check the situation of the control terminal S3 ● Check the parameter b05.00

Fault Code	Fault value	Fault Type	Reason	Solution
E022	0x16	AI1 Sensor Fault	1. Transducer disconnected; 2. Wrong transducer wiring; 3. Transducer short circuit; 4. Transducer break down	<ul style="list-style-type: none"> ● Check the cable between transducer and controller; ● Check the transducer whether is normal
E033	0x21	AI2 Sensor Fault	1. Transducer disconnected; 2. Wrong transducer wiring; 3. Transducer short circuit; 4. Transducer break down	<ul style="list-style-type: none"> ● Check the cable between transducer and controller; ● Check the transducer whether is normal



9.3 Controller Running Fault and Trouble Shooting

Fault Code	Fault value	Fault Type	Reason	Solution
E001	0x01	Inverter unit fault	1. Acc/Dec time is too short; 2. IGBT module fault; 3. Malfunction caused by interference; 4. Grounding is not properly	<ul style="list-style-type: none"> ● Increase Acc/Dec time; ● Check external equipments and eliminate interference; ● Ask supplier for support
E002	0x02	Over-current When Acceleration	1. Acceleration time is too short; 2. Low input voltage; 3. There are impurities in the pump; 4. Pump blocked;	<ul style="list-style-type: none"> ● Prolong acceleration time; ● Check the power supply; ● Check water quality and water intake environment ; ● Check motor;
E003	0x03	Over-current When Deceleration	1. Dec time is too short; 2. Load is too heavy; 3. The power of controller is small	<ul style="list-style-type: none"> ● Prolong Dec. time; ● Increase braking unit; ● Select bigger capacity controller
E004	0x04	Over-current When Constant Speed Running	1. Sudden change of load; 2. Low input voltage; 3. The power of controller is small	<ul style="list-style-type: none"> ● Check the load; ● Check the power supply; ● Select bigger capacity controller
E005	0x05	Over-voltage When Acceleration	1. High input voltage; 2. Regenerative energy from the motor is too large	<ul style="list-style-type: none"> ● Check the power supply; ● Avoid to restart the motor until it stop running completely
E006	0x06	Over-voltage When Deceleration	1. Dec time is too short; 2. Load is too heavy;	<ul style="list-style-type: none"> ● Increase Dec. time; ● Increase braking unit;
E007	0x07	Over-voltage When Constant Speed Running	1. High input voltage; 2. Load is too heavy	<ul style="list-style-type: none"> ● Install input reactor; ● Increase braking unit
E009	0x09	DC Bus Under-voltage	1. Low input voltage	<ul style="list-style-type: none"> ● Check the grid's input power supply
E010	0x0A	Controller Overload	1. Acceleration time is too short; 2. Low input voltage 3. Restart the motor when it does not	<ul style="list-style-type: none"> ● Increase acceleration time; ● Check the power supply; ● Avoid restarting during

Fault Code	Fault value	Fault Type	Reason	Solution
			stop totally;	shutdown;
E011	0x0B	Motor Overload	1.Low input voltage; 2.Wrong setting of motor parameter; 3.Motor blocked or something stick in the pump;	<ul style="list-style-type: none"> ● Check the power supply; ● Reset the rated current of motor; ● Check motor;
E012	0x0C	Input Phase Failure	1.Open-phase occurred at R, S,T power input side;	<ul style="list-style-type: none"> ● Check the wiring, installation and the power supply;
E013	0x0D	Output Phase Failure	1.Open-phase occurred at U,V,W output side (or there is asymmetric of load three phase)	<ul style="list-style-type: none"> ● Check the output wiring; ● Check the motor and cable;
E014	0x0E	IGBT Overheat	1.Cooling fans of controller blocked or damaged; 2.Ambient temperature is too high; 3.Wires or connectors of control board are loose; 4.Control board is abnormal	<ul style="list-style-type: none"> ● Clear air duct or replace cooling fans; ● Decrease the ambient temperature; ● Check wiring connection and reconnect; ● Ask supplier for support;
E016	0x10	RS485B Communication Timeout	1.The upper controller works abnormally; 2.Communication line is abnormal; 3.Wrong setting of communication parameter;	<ul style="list-style-type: none"> ● Check wiring connection of upper controller; ● Check communication wiring; ● Setting correct communication parameters;
E018	0x12	Current Detection Fault	1.Wires or connectors of control board are loose; 2.Abnormal current detection circuit;	<ul style="list-style-type: none"> ● Check wiring connection and re-wire; ● Ask supplier for service
E021	0x15	EEPROM Fault	1.Error occurred in the read-write of control parameters; 2.EEPROM damaged	<ul style="list-style-type: none"> ● Press STOP button to reset; ● Ask supplier for service

9. COMMUNICATION PROTOCOL

The W713B RS485B supports MODBUS RTU protocol, which is used for the controller or water supply system running state information and related function parameter setting.

Note: In the stop state, pressing  and  key at the same time in the primary display interface can realize Auto/Manual switchover.

1. Communication Terminal

Category	Terminal Symbol	Description of Function
485B Communication	485B+	485 Communication Input Terminal
	485B-	

Remark: For Multi-Pump Linkage System, only need to connect with #0 and #1 pump controller/inverter under Auto Mode.

2. Jumper

Jumper Nos.	Description of Goods
P3	485B Communication Terminal Resistance Selection, ON stands for getting through terminal resistance, otherwise switch off terminal resistance. Remark: For Multi-Pump linkage system, only need to get through terminal resistance of the first pump controller/inverter and the last one.

3. The communication parameters are as follows. Set them based on site requirements

Function Code	Name of Function	Range	Description
b03.10	Communication Address (RS485B)	1~250	Set the equipment communication address according to actual requirements: 1~250
b03.11	Baud Rate (RS485B)	Upper Computer Confirmed	Rate of data signaling 0: 1200BPS; 1: 2400BPS; 2: 4800BPS; 3: 9600BPS; 4: 19200BPS; 5: 38400BPS
b03.12	Data Check (RS485B)	Upper Computer Confirmed	0: No Check (8-N-2); 1: Even Parity Check (8-E-1) 2: Odd Check (8-O-1); 3: No Check (8-N-1)

4. Data address and status parameter

Data address please refer to the last column of Chapter 6 (Functional Parameter).

Status parameter please refer to list of 《Status Parameter Address》 as below:

《Status Parameter Address List》

Parameter Function	Address	Meaning of Value	R/W
Control Command (Both valid for Auto/Manual Mode)	1000H	0001H: Run	W/R
		0003H: Stop	
		0004H: The current inverter fault resetting	
		0005H: #1 Slave Inverter fault resetting	
		0006H: #2 Slave Inverter fault resetting	
		0007H: #3 Slave Inverter fault resetting	
		0008H: #4 Slave Inverter fault resetting	
		0009H: #5 Slave Inverter fault resetting	
Status (Both valid for Auto/Manual Mode)	1001H	0001H: In service	R
		0003H: Standby	
		0004H: In malfunction	
Communication Setting (Only valid for Manual Mode)	2000H	Communication Setting Range (-10000~10000) Note: The communication setting is the percentage of the relative value (-100.00%~100.00%). If it is set as frequency source, the value is the percentage of the maximum frequency .	W/R
Status Parameters (Both valid for	3000H	Output frequency	R
	3001H	Reference frequency	R

Auto/Manual Mode)	3002H	DC Bus voltage	R
	3003H	Output voltage	R
	3004H	Output current	R
	3005H	Rotation speed	R
	3006H	Output power	R
	3007H	Output torque	R
	3008H	Input terminal status	R
	3009H	Output terminal status.	R
	300AH	Input of AI1	R
	300BH	Input of AI2	R
	300CH	Accumulative running time	R
Multi-Pump Linkage Status Parameter (Only valid for Auto Mode)	4000H	Preset pressure /preset differential pressure /preset temperature /preset differential temperature	R
	4001H	Actual pressure /actual differential pressure /actual Temperature /actual differential temperature	R
	4002H	The actual pressure /temperature of pump inlet	R
	4003H	Alternated period	R
	4004H	Reserved	R
	4005H	#1 Pump Running Frequency	R
	4006H	#2 Pump Running Frequency	R
	4007H	#3 Pump Running Frequency	R
	4008H	#4 Pump Running Frequency	R
	4009H	#5 Pump Running Frequency	R
	400AH	#6 Pump Running Frequency	R
	400BH	#1 Pump Output Current	R
	400CH	#2 Pump Output Current	R
	400DH	#3 Pump Output Current	R
	400EH	#4 Pump Output Current	R
	400FH	#5 Pump Output Current	R
	4010H	#6 Pump Output Current	R
	4011H	#1 Pump Output Voltage	R
	4012H	#2 Pump Output Voltage	R
	4013H	#3 Pump Output Voltage	R
	4014H	#4 Pump Output Voltage	R
	4015H	#5 Pump Output Voltage	R
	4016H	#6 Pump Output Voltage	R
	4017H	#1 Pump Output RPM	R
	4018H	#2 Pump Output RPM	R
	4019H	#3 Pump Output RPM	R
	401AH	#4 Pump Output RPM	R
	401BH	#5 Pump Output RPM	R
	401CH	#6 Pump Output RPM	R
	401DH	#1 Pump Output Power	R
401EH	#2 Pump Output Power	R	

	401FH	#3 Pump Output Power	R
	4020H	#4 Pump Output Power	R
	4021H	#5 Pump Output Power	R
	4022H	#6 Pump Output Power	R
	4023H	Pump System Status 0: stop; 1: run; 2: malfunction	R
	4024H	#1 Pump Status 0: stop; 1: run; 2: malfunction; 3: standby	R
	4025H	#2 Pump Status 0: stop; 1: run; 2: malfunction; 3: standby	R
	4026H	#3 Pump Status 0: stop; 1: run; 2: malfunction; 3: standby	R
	4027H	#4 Pump Status 0: stop; 1: run; 2: malfunction; 3: standby	R
	4028H	#5 Pump Status 0: stop; 1: run; 2: malfunction; 3: standby	R
	4029H	#6 Pump Status 0: stop; 1: run; 2: malfunction; 3: standby	R
	402AH	Pump System Fault Information	R
	402BH	#1 Pump Fault Information	R
	402CH	#2 Pump Fault Information	R
	402DH	#3 Pump Fault Information	R
	402EH	#4 Pump Fault Information	R
	402FH	#5 Pump Fault Information	R
	4030H	#6 Pump Fault Information	R
Fault Info Address (Both valid for Auto/Manual Mode)	5000H	This address stores the Fault type of inverter. The meaning of each value is same as fault type of function code menu, but feedback hexadecimal data not error code. For example, E013 stands for output phase failure, the feedback is 0D.	R
Modbus Communication Fault Info Address (Both valid for Auto/Manual Mode)	5001H	0000H: No fault 0001H: Wrong password 0002H: Command code error 0003H: CRC error 0004H: Invalid address 0005H: Invalid data 0006H: Parameter change invalid 0007H: System locked 0008H: Busy (EEPROM is storing)	R



Agent:

<http://www.bedford.com.cn>